

Section 10

PARTS

SPARE PARTS RECOMMENDATIONS**PART LIST****SPARE PARTS RECOMMENDATIONS**

The following table lists the common spare parts we suggest you purchase in advance:

Part Name	Part Name
Saw blade	Coolant tank filter
Wire brush	Steel plates
Carbide inserts	Rollers
Bearings	Belt
Hydraulic tank leak-proof gasket	Duster seal
Rubber washer	Snap ring
Oil seal	O-ring

MACHINERYHOUSE



PART LIST

Section 10

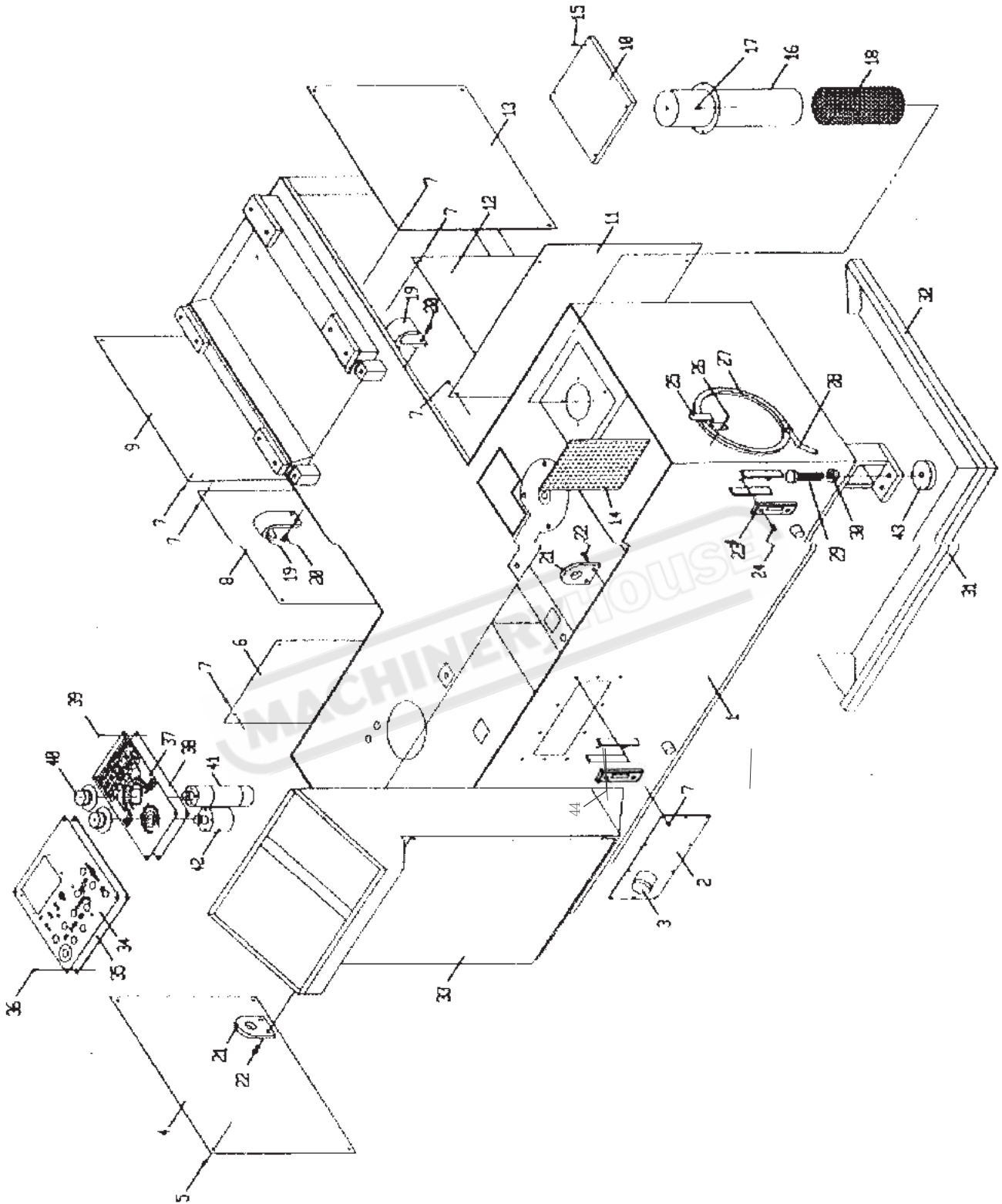

AGC-1001 MACHINE BODY ASSEMBLY

Fig 1 MACHINE FOUNDATION ASSEMBLY



PART LIST

Section 10

NO.	PART NO.	PART NAME	PART NAME IN CHINESE	PART SPEC.	Q'TY
1-1	AGC-1001	base seat	底座		1
1-2	AHA-0102	oil tank cover	油箱蓋		1
1-3	PP-90857	cap	油箱蓋螺帽		1
1-4	AGC-1057A	left elec.box cover	左電氣箱蓋		1
1-5		screw	丸頭螺絲	M6*6L	4
1-6	AGC-1054	left rear cover	底座左後蓋		1
1-7		screw	丸頭螺絲	M6*5L	34
1-8	AGC-1052	left cover	底座左蓋		1
1-9	AGC-1053	side cover	底座邊蓋		1
1-10	AGC-1059	coolnat pump cover	水邦浦護蓋		1
1-11	AGC-1050A	right rear cover	底座右後蓋		1
1-12	AGC-1051	right cover	底座右蓋		1
1-13	AGC-1053	side cover	底座邊蓋		1
1-14	AHA-0138	filter	水箱通道濾網		1
1-15		bolt	內六角螺絲	M5*5L	4
1-16	PP-32081	pump	浸水泵浦	1/8HP*210L	1
1-17		bolt	外六角螺絲	M6*10L	4
1-18	AHA-0131	filter	浸水泵浦濾網		1
1-19	AHC-0160	hanger	吊耳(三)		2
1-20		bolt	外六角螺絲	M10*20L	4
1-21	AHC-0161	hanger	吊耳(四)		2
1-22		bolt	外六角螺絲	M10*20L	4
1-23	PP-21030A	Water gauge	水面計	3"	1
1-24		bolt	螺絲		4
1-25	AHA-1309	bracket	軟管架		1
1-26		bolt	內六角螺絲	M6*6L	2
1-27		cable duct	護管	3/8*1000L	1
1-28	AHA-1313	nozzle	噴嘴		1
1-29	AHC-0153	adjusting bolt	底座調整螺絲		6
1-30		nut	螺帽	M20	6
1-31	AHC-1503-NC	right front plate	右前擋板		1
1-32	AHC-1504-NC	right side plate	右側擋板		1
1-33	AHC-0131-CE	elec.box	電氣箱		1
1-34	AGC-1040B	elec.data plate	控制面板		1
1-35	AGC-1041B	control plate	控制底板		1
1-36		screw	丸頭螺絲	M8*8L	4
1-37	AHC-0134-CE	elec.data plate	控制面板		1
1-38	AHC-0135-CE	control plate	控制底板		1
1-39		screw	丸頭螺絲	M8*8L	4
1-40	AHA-1806	vernier dial	流量閥旋鈕		2
1-41	AHA-10289	regulator set	調壓閥		1
1-42	AHA-6100	flow control valve	流量控制閥		1
1-43	AHR-1055	base support	底座墊塊		6
1-44	PP-21030	oil sight gauge	油面計 (含刻度表)	3"	1
1-45					
1-46					

Fig 1 MACHINE FOUNDATION ASSEMBLY



PART LIST

Section 10

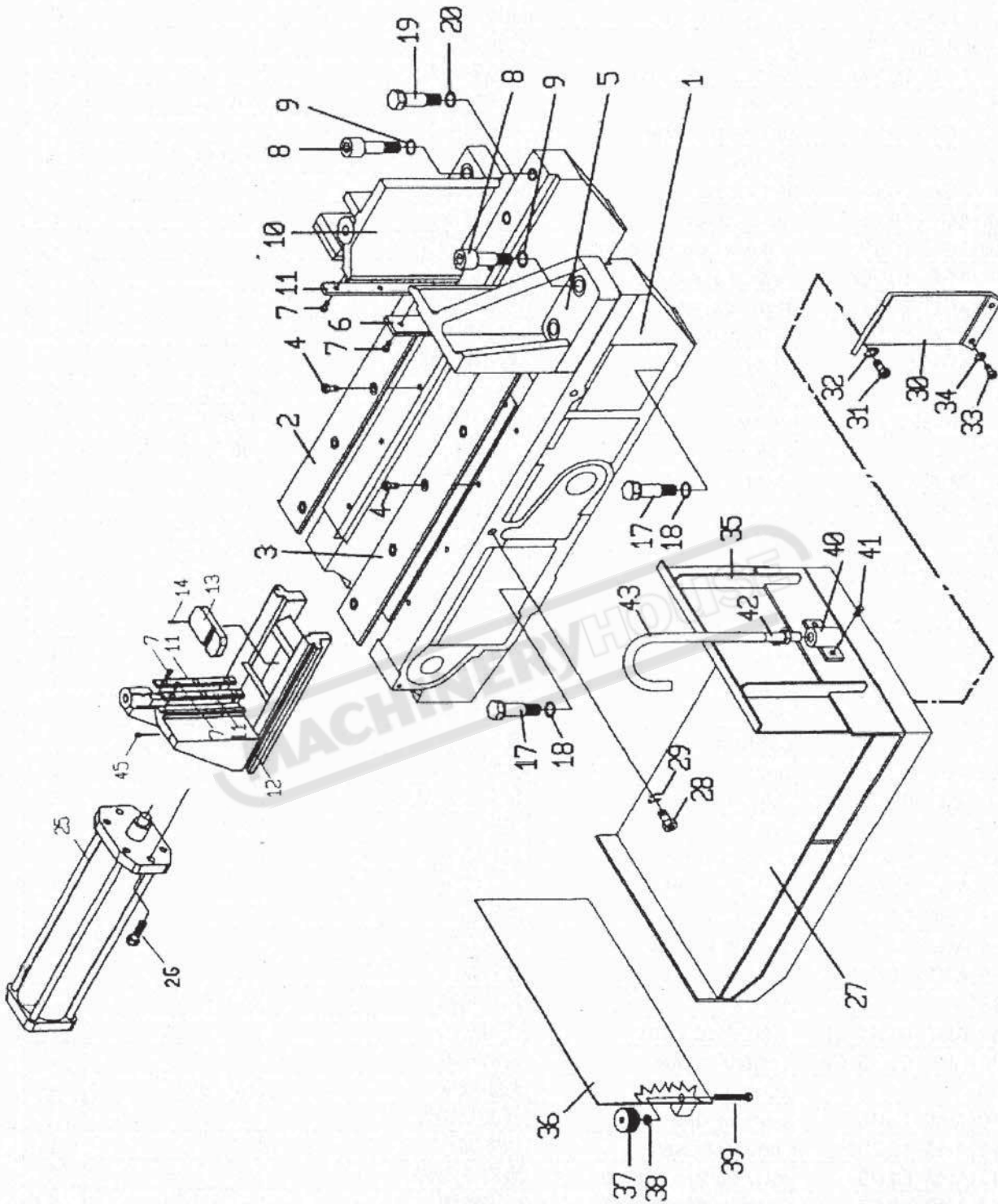

AGC-1002D BED ASSEMBLY

Fig 2 BED ASSEMBLY



PART LIST

Section 10

NO.	PART NO.	PART NAME	PART NAME IN CHINESE	PART SPEC.	Q'TY
2-1	AHC-0201	vise bed	床面		1
2-2	AHC-0234B	slide plate	床面鋼板		1
2-3	AHC-0234A	slide plate	床面鋼板		1
2-4		bolt	內六角螺絲	M8*20L	10
2-5	AHC-0230	front fixed vise jaw	前固定虎鉗(二)		1
2-6	AHC-0238	vise plate	虎鉗鋼板		1
2-7		bolt	內六角螺絲	M6*16L	12
2-8	AHA-0122B	fixed bolt	固定螺絲(二)		4
2-9		spring washer	彈簧華司		4
2-10	AHC-0229	front fixed vise jaw	前固定虎鉗(一)		1
2-11	AHC-0239B	vise plate	虎鉗鋼板		3
2-12	AHC-0223-NC	front movable vise jaw	前活動虎鉗		1
2-13	AHA-0227A	auxiliary plate	輔助板		3
2-14		spring pin	彈簧銷	φ6*16L	2
2-15	AHA-0224	pawl	施力板		1
2-16	AHA-0225A	straight pin	施力板插銷		1
2-17	AHA-0122A	fixed bolt	固定螺絲(一)		2
2-18		washer	華司	M16	2
2-19		bolt	外六角螺絲	M14*45L	2
2-20		spring washer	彈簧華司	M14	2
2-21	AHB-0215C	rack	浪形板		1
2-22	AHA-0210B	rack guide ring	浪形板活動圈		1
2-23		spring washer	彈簧華司	M8	1
2-24		bolt	內六角螺絲	M8*20L	1
2-25	AHA-02139-1	vise cylinder	虎鉗油壓缸		1
2-26		spring pin	彈簧銷	φ6*35L	1
2-27	AGC-1035	stock receiving tray	托架		1
2-28		bolt	內六角螺絲	M12*30L	2
2-29		spring washer	彈簧華司	M12	2
2-30	AHC-1437	support	托架支持板		1
2-31		bolt	內六角螺絲	M10*15L	2
2-32		spring washer	彈簧華司	M10	2
2-33		bolt	內六角螺絲	M6*15L	2
2-34		spring washer	彈簧華司	M6	2
2-35	AHC-1424	right fence	托架右板		1
2-36	AHC-1423-CE	left fence	托架左板		1
2-37	SJM-4029	Nut	普利護蓋螺母		2
2-38		Nut	螺帽	M8	2
2-39		Bolt	內六角螺絲	M8*100L	2
2-40	AGB-70220	Bracket	冷卻水管固定板		1
2-41		Bolt	內六角螺絲	M5*12L	2
2-42	PP-43136	Valve	開關閥	A103 PT 3/8	1
2-43	PP-57079	Hose	出水管	3/8*25"	1
2-44					
2-45		set screw	止付螺絲	M6*8L	1
2-46					

Fig 2 BED ASSEMBLY



PART LIST

Section 10

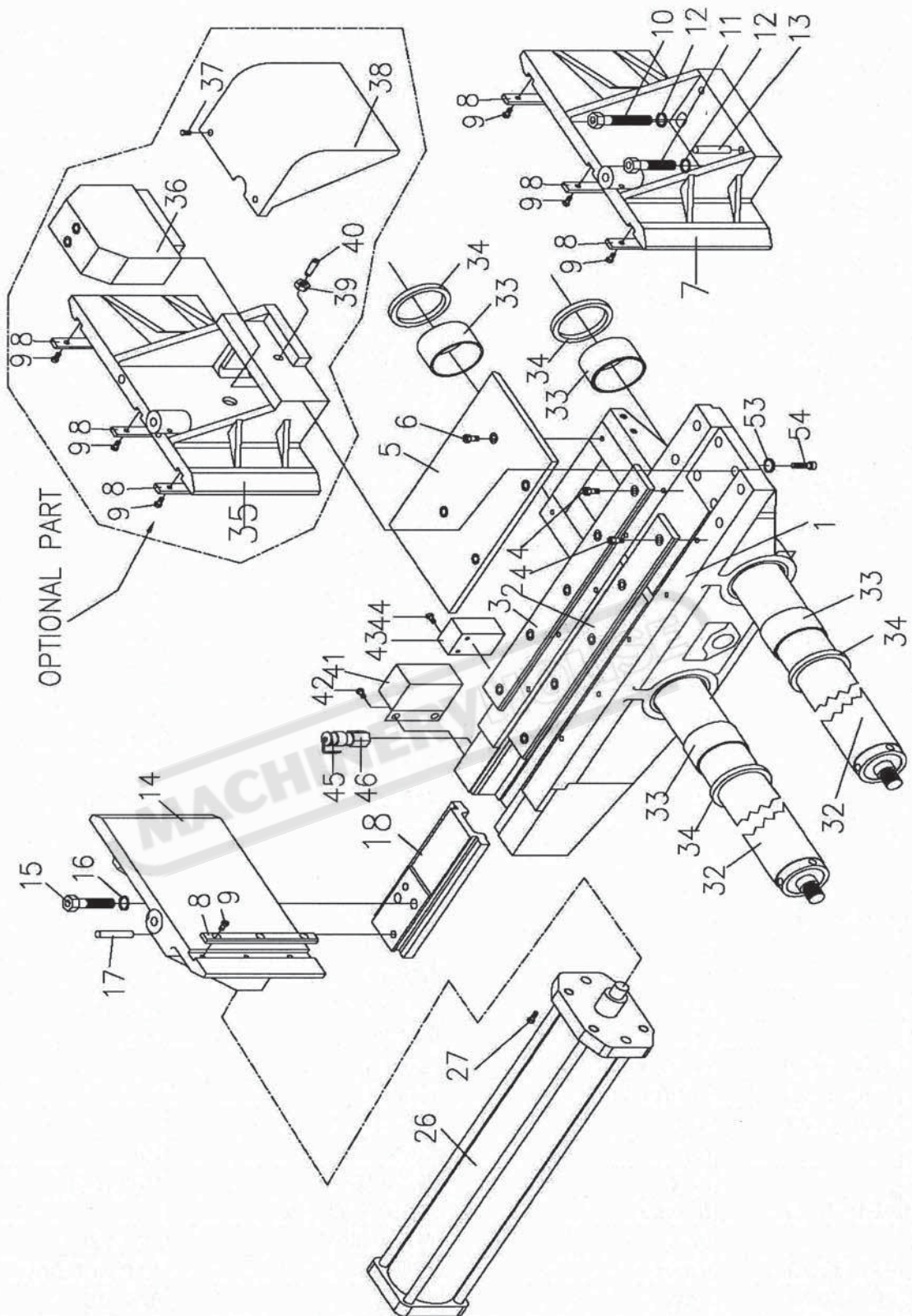

AGC-1003D WORK FEED BED ASSEMBLY

Fig 3 WORK FEED BED ASSEMBLY



PART LIST

Section 10

NO.	PART NO.	PART NAME	PART NAME IN CHINESE	PART SPEC.	Q'TY
3-1	AHC-1510	feed vise bed	自動送料座		1
3-2	AHC-1513	slide plate	送料床面鋼板		1
3-3	AHC-1513	slide plate	送料床面鋼板		1
3-4	PDA-8-20	bolt	內六角螺絲	M8*20L	10
3-5	AHC-15241Y1	plate	遮板		1
3-6		bolt	內六角螺絲	M8*20L	4
3-7	AHC-1527	rear fixed vise jaw	後固定虎鉗		1
3-8	AHC-0239D	vise plate	前活動虎鉗鋼板		4
3-9		bolt	內六角螺絲	M6*16L	12
3-10		bolt	內六角螺絲	M16*60L	1
3-11		bolt	內六角螺絲	M16*40L	1
3-12		spring washer	彈簧華司	M16	2
3-13		taper pin	斜度銷	Ø10 X 50L	2
3-14	AHC-1520A	rear movable vise jaw	後活動虎鉗		1
3-15	PBA-16-60	bolt	內六角螺絲	M16*25L	2
3-16	PQA-16	washer	華司	M16	2
3-17	PRB-10-50	taper pin	斜度銷	Ø10 X 50L	2
3-18	AHA-1518	vise body	虎鉗滑座		1
3-19	AHA-0224	pawl	施力板		1
3-20	AHA-0225B	straight pin	施力板插銷		1
3-21		set screw	止付螺絲	M6*8L	1
3-22	AHB-0215C	rack	浪形板		1
3-23	AHA-0210B	rack guide ring	浪形板活動圈		1
3-24		spring washer	彈簧華司	M8	1
3-25		bolt	內六角螺絲	M8*20L	1
3-26	AHA-02139-1	vise cylinder	虎鉗油壓缸		1
3-27		spring pin	彈簧銷	Ø6 X 35L	1
3-28	AHC-1544-CE	lever	開關擋板(一)		1
3-29		bolt	外六角螺絲	M8*30L	1
3-30		nut	螺帽	M8	1
3-31		bolt	外六角螺絲	M6*15L	2
3-32	AHA-1601B	feed shaft	送料軸		2
3-33	PP-13260	du bushing	乾式軸承	6540	4
3-34	PP-51146	dust seal	防塵套	65*79*8/11	4
3-35	AGC-2202T	Rear fixed vise	後固定虎鉗		1
3-36	AGC-2200-1	Rear fixed cylinder assy	後虎鉗固定油壓缸組		1
3-37	PFA-5-10	Oval head screw (+)	丸頭螺絲(十字)(公)	Φ 5 x 10 mm	2
3-38	AGC-2209	Vise cover	固定虎鉗蓋		1
3-39	POA-12-175	Nut	螺母(公)	12 mm Φ x P 1.75	1
3-40	PAA-12-50	Set screw	止付螺絲(公)	M12 x P1.75 x 50	2
3-41		limit switch	限動開關	ZCK-M	1
3-42		bolt	內六角螺絲	M6*12L	2
3-43		limit switch	限動開關	ZCK-J	1
3-44		bolt	內六角螺絲	M6*12L	2
3-45	AHA-1932	dust seal	防塵套(母)		1
3-46	PP-21099	connect	快速接頭	1/4"	1
3-53	PQA-12	spring washer	彈簧華司(公)	Φ 12 mm	4
3-54	PBA-12-25	Hex soc cap screw	有頭內六角螺絲(公)	M12 x P1.75 x 25	2
	PBA-12-30	Hex soc cap screw	有頭內六角螺絲(公)	M12 x P1.75 x 30	2



PART LIST

Section 10

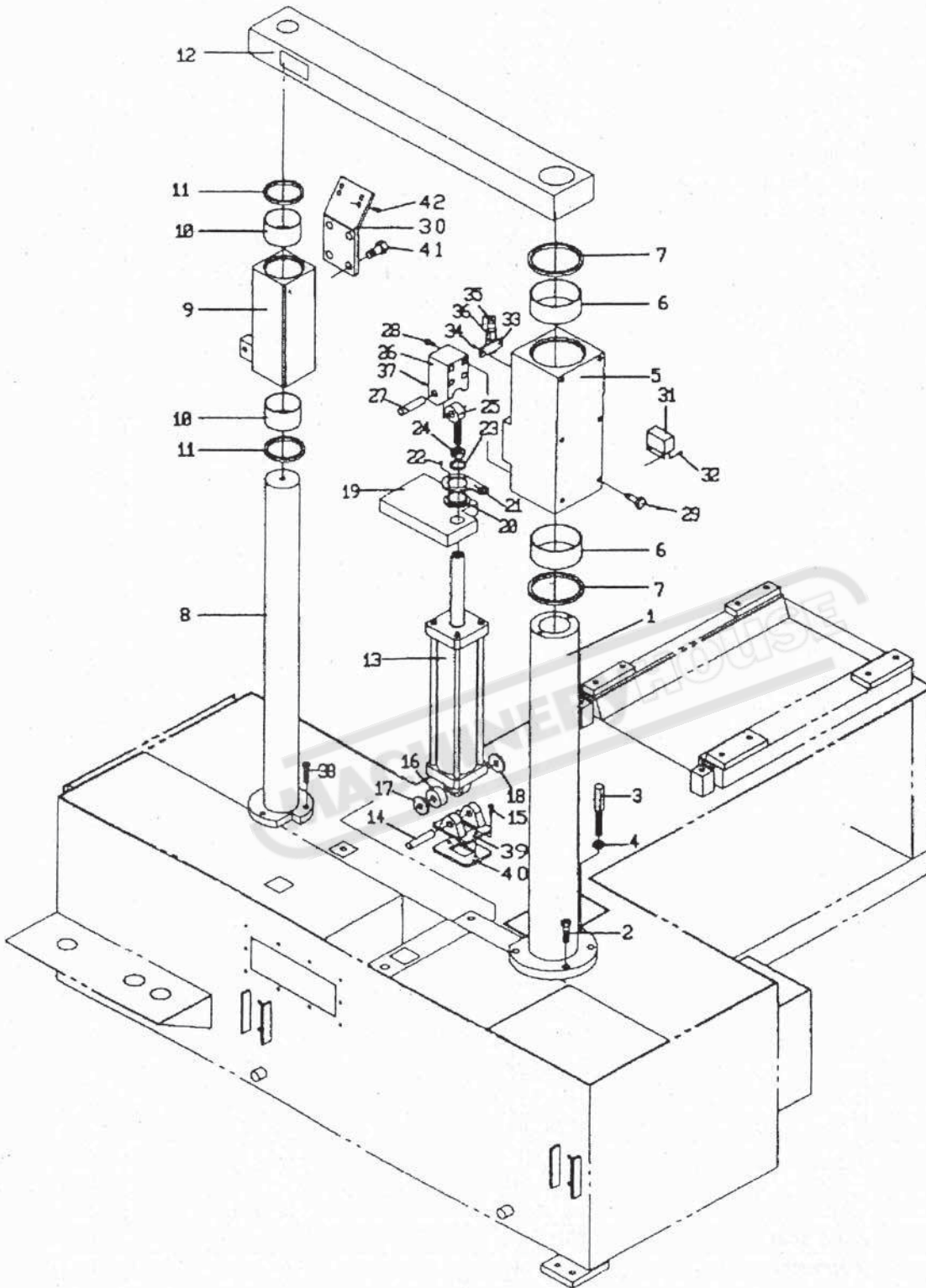

AGC-1004 MAIN SHAFT & SUB SHAFT ASSEMBLY

Fig 4 MAIN SHAFT & SUB SHAFT ASSEMBLY



PART LIST

Section 10

NO.	PART NO.	PART NAME	PART NAME IN CHINESE	PART SPEC.	Q'TY
4-1	AGC-1010	main shaft	大主軸		1
4-2		bolt	內六角螺絲	M16*50L	3
4-3	AGC-1030	bolt	下限定位支桿		1
4-4		nut	螺帽	M16	1
4-5	AGC-3009	main shaft sleeve	大軸套		1
4-6	PP-13310	du bushing	乾式軸承	11050	2
4-7	PP-51140	dust seal	防塵套	110*126*9	2
4-8	AGC-1011	sub shaft	小主軸		1
4-9	AGC-3010	sub shaft sleeve	小軸套		1
4-10	PP-13281	du bushing	乾式軸承	8050	2
4-11	PP-51196	dust seal	防塵套	80*94*8	2
4-12	AGC-1012	cross link	主軸樑		1
4-13	AGC-10200	housing yoke cylinder	鋸弓油壓缸		1
4-14	AGB-70304B	pin	鋸弓油缸下插銷		1
4-15		bolt	內六角螺絲	M8*15L	2
4-16	PP-14510	bearing	軸承	2303	1
4-17	AHA-1105A	washer	活動軸墊圈		1
4-18	AHA-1105	washer	橡膠墊圈		1
4-19	AGC-1018A	cover	鋸弓油缸護罩		1
4-20	AGC-1022	conceal ring	鋸弓油缸遮環		1
4-21	AGC-1029	fixed plate	底座油封固定板		1
4-22		bolt	內六角螺絲	M4*15L	4
4-23	PP-51018	oil seal	油封	30*40*5	1
4-24		nut	螺帽	M18	1
4-25	PP-14480	link bearing	連桿軸承	POS 18	1
4-26	AGC-3011	cylinder upper ear	鋸弓油缸上耳		1
4-27	AGB-70304A	pin	鋸弓油缸上插銷		1
4-28		bolt	內六角螺絲	M10*35L	4
4-29	AGC-1013	bolt	大軸套定位螺絲		2
4-30	AGC-3012	bracket	小軸套固定板		1
4-31		limit switch	限動開關	ZCK-M	1
4-32		bolt	內六角螺絲	M5*12L	2
4-33	AGB-70220	coolant bracket	冷卻水管固定板		1
4-34		bolt	內六角螺絲	M5*12L	2
4-35	AHA-1932	dust seal	母防塵套		1
4-36	PP-21099	connect	快速接頭	1/4"	1
4-37		set screw	止付螺絲	M6*6L	1
4-38		bolt	內六角螺絲	M12*40L	3
4-39	AGC-1031	hydraulic holder	油壓缸固定座		1
4-40	AGC-1032	hydraulic holder plate	油壓缸固定座板		1
4-41		bolt	內六角螺絲	M22*30L	4
4-42		bolt	內六角螺絲	M8*20L	4
4-43					
4-44					
4-45					
4-46					

Fig 4 MAIN SHAFT & SUB SHAFT ASSEMBLY



PART LIST

Section 10

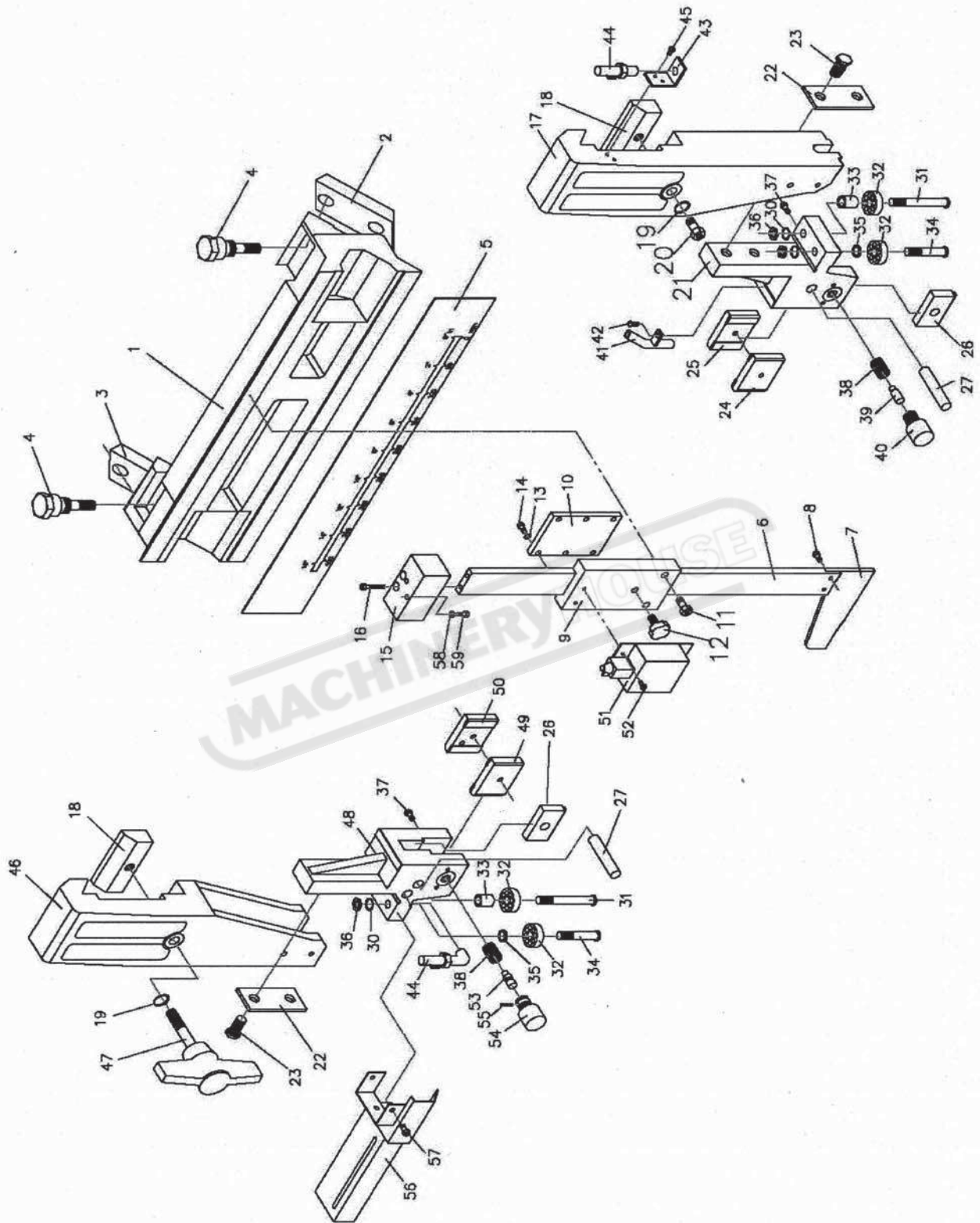

AGC-1008-CE GUIDE BRACKET ASSEMBLY

Fig 8 GUIDE BRACKET ASSEMBLY



PART LIST

Section 10

NO.	PART NO.	PART NAME	PART NAME IN CHINESE	PART SPEC.	Q'TY
8-1	AHC-0738	guide bar	鋸臂滑板		1
8-2	AHA-0439B	slide tip (2)	鋸臂滑板固定塊(二)		1
8-4	AHA-0734	adjusting bolt	滑板調整螺絲		4
8-3	AHA-0439A	slide tip (1)	鋸臂滑板固定塊(一)		1
8-5	AGC-3018	ruler plate	鋸臂滑板銘牌		1
8-6	AHC-1753B	descending slide bar	急降桿		1
8-7	AHA-1755C	feeder	急降桿擋板		1
8-8		bolt	內六角螺絲	M6*10L	2
8-9	AHA-1752	descending slide bracket	急降桿固定座		1
8-10	AHA-1754	cover plate	急降桿座蓋		1
8-11		bolt	內六角螺絲	M10*30L	2
8-12	PP53010	screw	梅花螺絲	M8*20L	1
8-13		spring washer	彈簧華司	M6	3
8-14		bolt	內六角螺絲	M6*12L	3
8-15	AHA-1756	limit block	限動開關座		1
8-16		bolt	內六角螺絲	M6*40L	2
8-17	AHC-0749	right guide bracket	右鋸臂		1
8-18	AHA-0737	slide tip	鋸臂固定塊		2
8-19		spring washer	彈簧華司	M12	1
8-20		bolt	外六角螺絲	M12*75L	1
8-21	AHA-0748B	right insert holder	右導輪座		1
8-22	AHA-0719	plain washer	導輪座墊片		2
8-23		bolt	外六角螺絲	M12*40L	4
8-24	AHA-0743B	right movable insert	右活動錫鋼片		1
8-25	AHA-0744B	right fixed insert	右固定錫鋼片		1
8-26	AHA-0704A	Pressure block	下壓錫鋼片塊座		2
8-27	AHA-0713-1	Shaft	下壓錫鋼片短軸		2
8-28				Deleted	
8-29				Deleted	
8-30		spring washer	彈簧華司	M10	1
8-31	AHA-0707B	roller pin	導輪軸		2
8-32	PP-14270	bearing	軸承	6200 VV	4
8-33	AHA-0708B	washer	墊圈		2
8-34	AHA-0707C	roller pin	短導輪軸		2
8-35		washer	墊圈	M10	2
8-36		nut	螺帽	M10	4
8-37		bolt	內六角螺絲	M6*20L	2
8-38	AHA-0710	spring	彈簧		2
8-39	AHA-0741	right fitting	右簧塞		1
8-40	AHA-0742	right insert knob	右調整螺絲		1
8-41	AHA-0745	coolant nozzle	冷卻水噴嘴		1
8-42		bolt	內六角螺絲	M5*8L	1
8-43	MJA-2041	bracket	水龍頭座板		1
8-44	PP-43132	coolant valve	開關閥	1/8"	2
8-45		bolt	內六角螺絲	M5*8L	2
8-46	AHC-0722	left guide bracket	左鋸臂		1

Fig 8 GUIDE BRACKET ASSEMBLY



PART LIST

Section 10

NO.	PART NO.	PART NAME	PART NAME I N CHINESE	PART SPEC.	Q'TY
8-47	AHA-07259	handle	把手		1
8-48	AHA-0712B	left insert holder	左導輪座		1
8-49	AHA-0702B	left movable insert	左活動鑄鋼片		1
8-50	AHA-0701B	left fixed insert	左固定鑄鋼片		1
8-51		limit switch	限動開關		1
8-52		bolt	內六角螺絲	M5*25L	2
8-53	AHA-0709	left fitting	左簧塞		1
8-54	AHA-0711	adjusting bolt	調整螺絲		1
8-55		pin	銷	φ3*16L	1
8-56	AGC-3020	movable saw blade cover	活動鋸片護蓋		1
8-57		bolt	內六角螺絲	M6*5L	1
8-58		nut	螺帽	M6	1
8-59		bolt	外六角螺絲	M6*35L	1
8-60					
8-61					
8-62					
8-63					
8-64					
8-65					
8-66					
8-67					
8-68					
8-69					
8-70					
8-71					
8-72					
8-73					
8-74					
8-75					
8-76					
8-77					
8-78					
8-79					
8-80					
8-81					
8-82					
8-83					
8-84					
8-85					
8-86					
8-87					
8-88					
8-89					
8-90					
8-91					
8-92					



PART LIST

Section 10

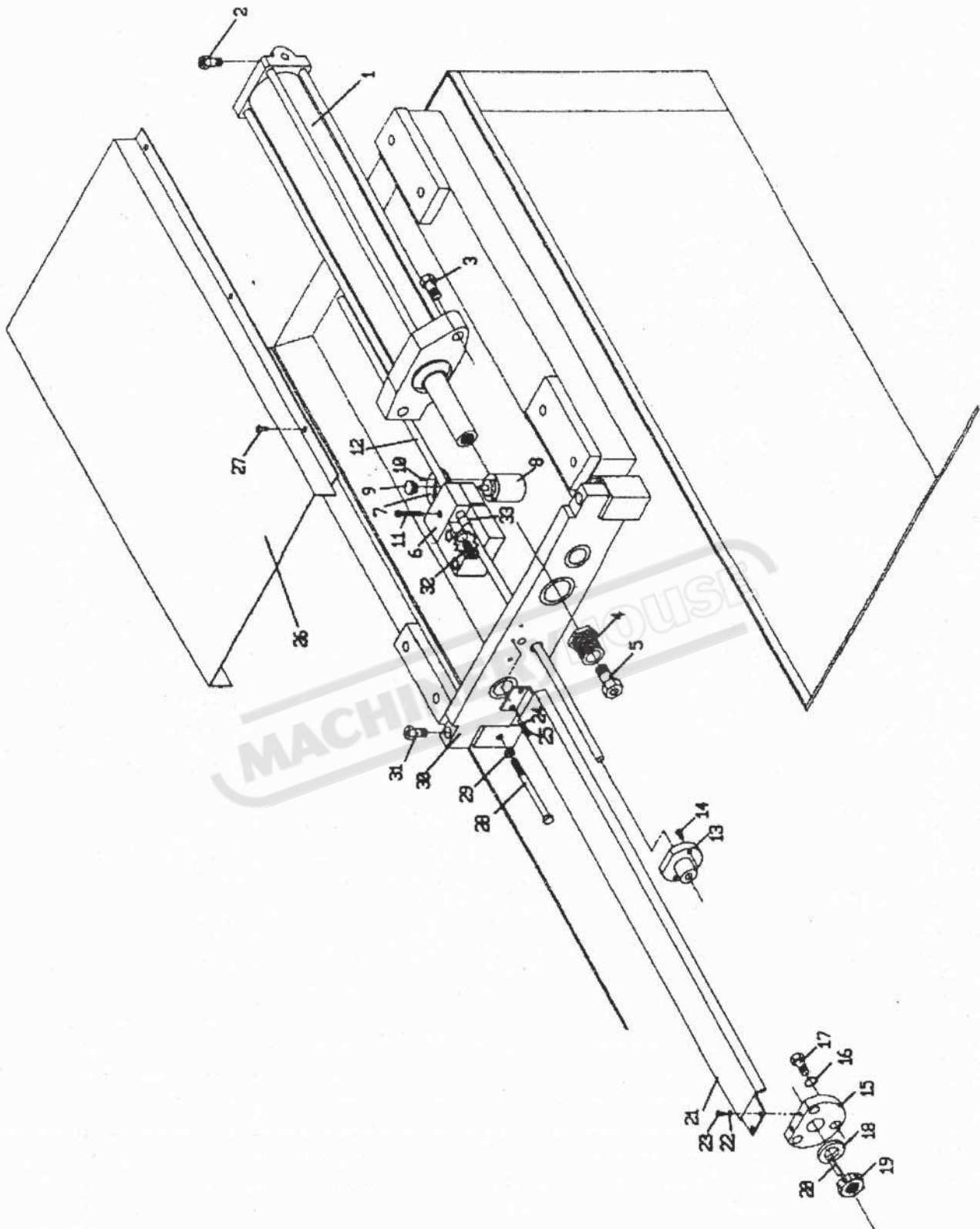

AGC-1010A ENCODER & FEEDING CYLINDER ASSEMBLY

Fig 10 ENCORE & FEEDING CYLINDER ASSEMBLY



PART LIST

Section 10

NO.	PART NO.	PART NAME	PART NAME IN CHINESE	PART SPEC.	Q'TY
10-1	AHA-16019-1	feed cylinder	送料油壓缸		1
10-2		bolt	內六角螺絲	M12*30L	1
10-3		bolt	內六角螺絲	M14*25L	2
10-4	AHA-1605	bush bolt	襯套螺絲		1
10-5		bolt	內六角螺絲	M18*60L	1
10-6	AHA-1563	encoder bracket	譯碼器固定座		1
10-7	AHA-1562	movable plate	譯碼器活動板		1
10-8	PP-90492	encoder	譯碼器	LBT-002-2000	1
10-9	AHA-1560	stop gear	定寸齒輪		1
10-10		bolt	內六角螺絲	M3*8L	3
10-11		bolt	內六角螺絲	M6*40L	1
10-12	AHA-1561-1	stop chain	定寸齒條		1
10-13	AHA-1564	encoder bracket (2)	齒排固定座(二)		1
10-14		bolt	內六角螺絲	M5*10L	2
10-15	AHA-1645	bearing holder	軸承座		1
10-16		spring washer	彈簧華司	M12	1
10-17		bolt	內六角螺絲	M12*30L	1
10-18	PP-14430,A,B	bearing	軸承	2035	1PC/EA
10-19	AHA-1643	nut	螺帽		1
10-20		pin	銷	φ5*25L	1
10-21	AHA-1641	cover	定寸螺桿護蓋		1
10-22		spring washer	彈簧華司	M5	2
10-23		bolt	內六角螺絲	M5*12L	2
10-24		spring washer	彈簧華司	M5	2
10-25		bolt	內六角螺絲	M5*12L	2
10-26	AGC-1038	cylinder cover	油壓缸護蓋		1
10-27		bolt	內六角螺絲	M5*8L	6
10-28		bolt	外六角螺絲	M8*100L	1
10-29		nut	螺帽	M8	1
10-30	AHC-1654	set plate	送料軸固定板		1
10-31		bolt	內六角螺絲	M12*50L	2
10-32	M3L-9-10	spring	彈簧		1
10-33	PP-13020	du bushing	乾式軸承	1012	2
10-34					
10-35					
10-36					
10-37					
10-38					
10-39					
10-40					
10-41					
10-42					
10-43					
10-44					
10-45					
10-46					

Fig 10 ENCORE & FEEDING CYCLINDER ASSEMBLY



PART LIST

Section 10

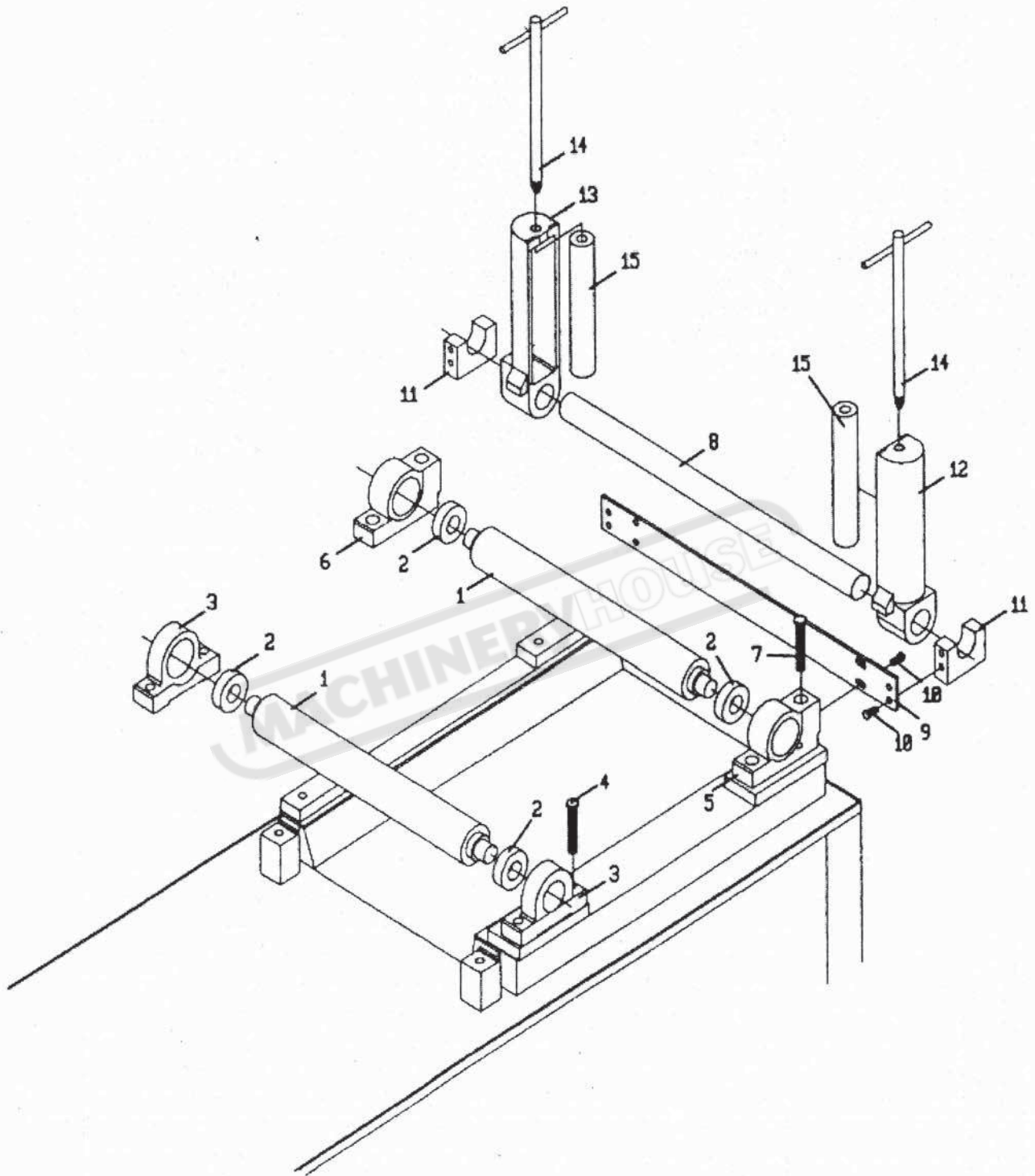

AGC-1012 WORK FEED ASSEMBLY

Fig 12 WORK FEED ASSEMBLY



PART LIST

Section 10

NO.	PART NO.	PART NAME	PART NAME IN CHINESE	PART SPEC.	QTY
12-1	AHB-1654	roller	滾輪		2
12-2	PP-14275	bearing	軸承	6205 ZZ	4
12-3	AHA-1636	roller bracket	滾輪固定座		2
12-4		bolt	內六角螺絲	M12*25L	4
12-5	AHB-1653	right roller bracket	右滾輪固定座		1
12-6	AHB-1691	left roller bracket	左滾輪固定座		1
12-7		bolt	內六角螺絲	M12*25L	4
12-8		guide bar	側滾輪固定軸		1
12-9		stopper plate	側滾輪擋板		1
12-10		bolt	內六角螺絲	M8*25L	8
12-11	AHB-1682	roller bracket	側滾輪固定座		2
12-12	AHB-1687	right roller bracket	右側滾輪座		1
12-13	AHB-1686	left roller bracket	左側滾輪座		1
12-14	AHB-1690	shaft	側滾輪軸		2
12-15	AHB-1688B	roller	側滾輪		2
12-16					
12-17					
12-18					
12-19					
12-20					
12-21					
12-22					
12-23					
12-24					
12-25					
12-26					
12-27					
12-28					
12-29					
12-30					
12-31					
12-32					
12-33					
12-34					
12-35					
12-36					
12-37					
12-38					
12-39					
12-40					
12-41					
12-42					
12-43					
12-44					
12-45					
12-46					

Fig 12 WORK FEED ASSEMBLY



PART LIST

Section 10

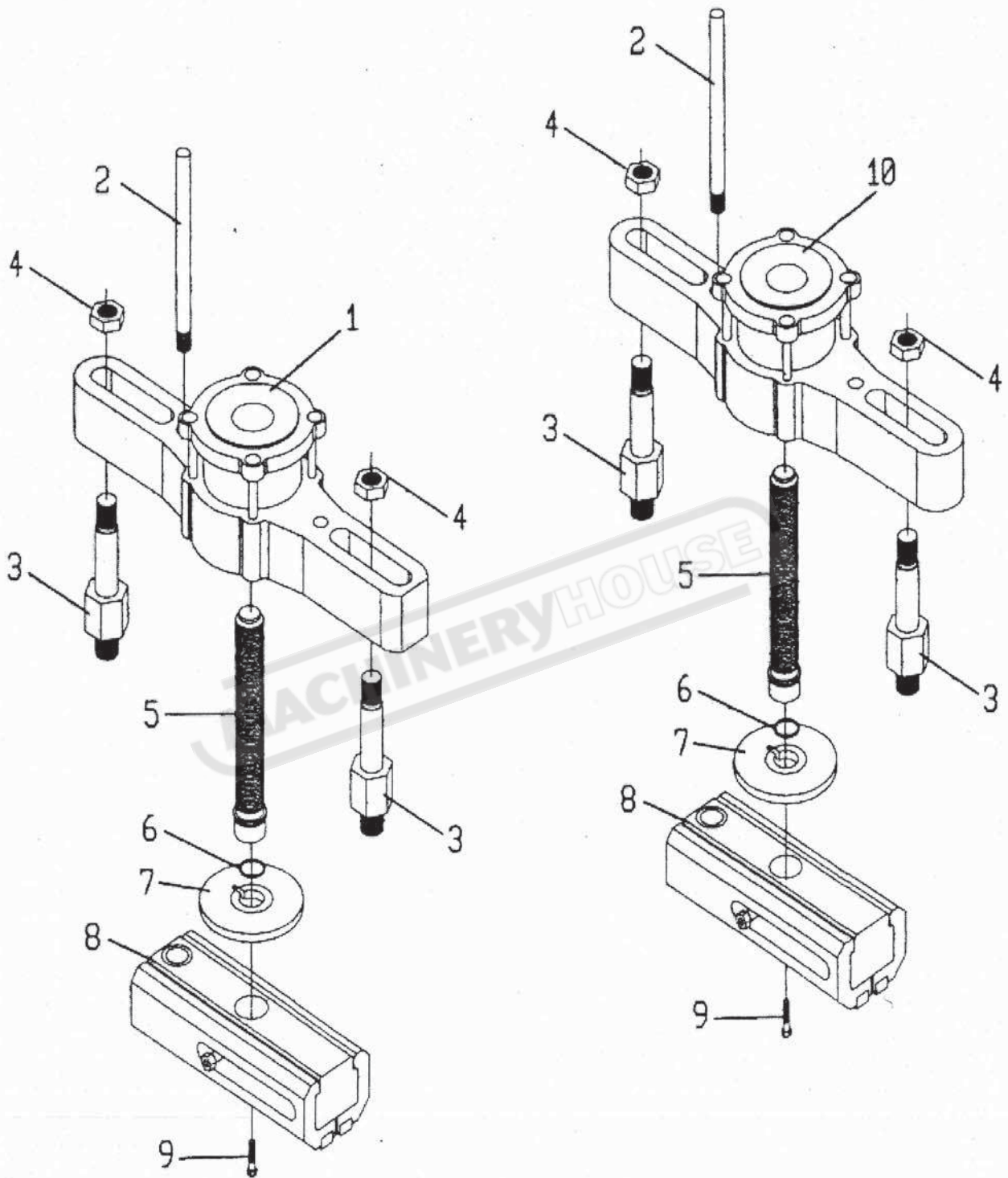

AGC-1012 WORK FEED ASSEMBLY

Fig 13 MULTI-VISE (OPTIONAL)



PART LIST

Section 10

NO.	PART NO.	PART NAME	PART NAME IN CHINESE	PART SPEC.	Q'TY
13-1	AHC-19038	front multi-vise cylinder	前下壓缸組		1
13-2	AHA-1908	rod	推把		2
13-3	AHA-1905	fixed bolt	固定螺栓		4
13-4		nut	螺帽	M14	4
13-5	AHC-1912	adjusting bolt	下壓調整螺桿		2
13-6		snap ring	扣環	S20	2
13-7	AHA-1923	adjusting handle	調整手輪		2
13-8	AHC-19240	clamper	下壓板組		2
13-9		bolt	內六角螺絲	M8*20L	2
13-10	AHC-19039	rear multi-vise cylinder	後下壓缸組		1
13-11					
13-12					
13-13					
13-14					
13-15					
13-16					
13-17					
13-18					
13-19					
13-20					
13-21					
13-22					
13-23					
13-24					
13-25					
13-26					
13-27					
13-28					
13-29					
13-30					
13-31					
13-32					
13-33					
13-34					
13-35					
13-36					
13-37					
13-38					
13-39					
13-40					
13-41					
13-42					
13-43					
13-44					
13-45					
13-46					

Fig 13 MULTI-VISE (OPTIONAL)



PART LIST

PART P
2M ROLLER TABLE (OPTIONAL)
PART NO : 05OPR-320-2M

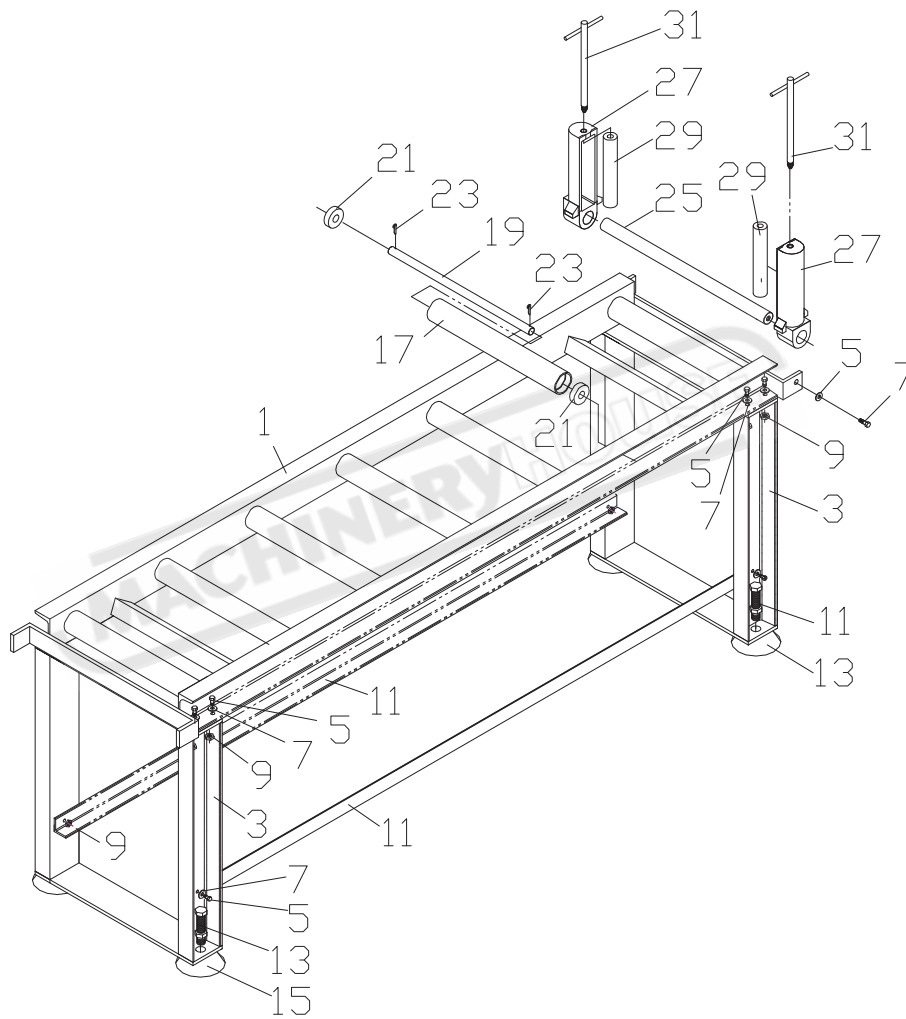



PART LIST

PART P

2M ROLLER TABLE (OPTIONAL)

PART NO : 05OPR-320-2M

ITEM	PART NO.	PART NAME	PART NAME (CH)	PART SPEC.	COUNT	UNIT
1	OPR-5002A	roller table	滾輪料架	(440W)	1	PCS
3	PLA-12-20	bolt	外六角螺絲	M12 x 20L	12	PCS
5	PPA-12	washer	平面華司(公)	M12	12	PCS
7	POA-12-175	nut	螺母	M12 xP1.75	8	PCS
9	OPR-5003AA	roller table frame	料架腳	440WX 770H	2	PCS
11	OPR-5004	angle bar	料架腳連桿		2	PCS
13	AHC-0152	adjusting bolt	送料架調整螺桿		4	PCS
15	AHR-1055	base support	底座墊塊		4	PCS
17	OPR-5001A	roller	滾輪	440W	7	PCS
19	OPR-5009A	shaft	滾輪軸	440W	7	PCS
21	PP-14297A	bearing	軸承	6304-ZZ URB	14	PCS
23	PUA-007-140	split pin	開口銷	3/32 x 1-1/2	14	PCS
25	OPR-5008A	side roller shaft	側滾輪滑軸	(440W) (D32*559L)	1	PCS
27	OPR-5015B	side roller bracket	側滾輪座	177L	2	PCS
29	OPR-5013B	roller	側滾輪	172L	2	PCS
31	OPR-5014B	shaft	側滾輪軸及把手	265L	2	PCS

MACHINERYHOUSE



PART LIST

Section 10

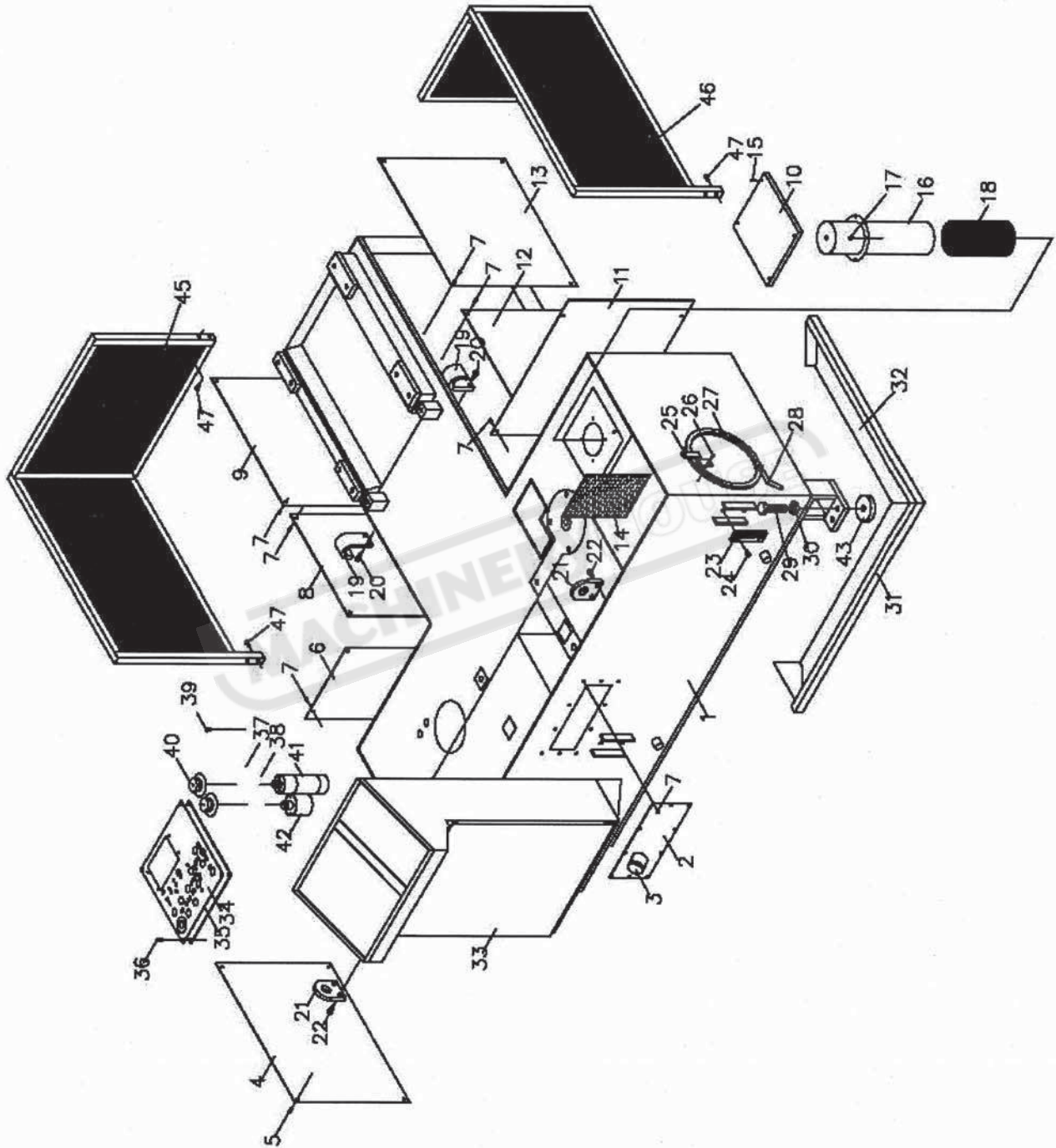

AGC-1001 MACHINE BODY ASSEMBLY

Fig 15 MACHINE FOUNDATION ASSEMBLY(FOR CE)



PART LIST

Section 10

NO.	PART NO.	PART NAME	PART NAME IN CHINESE	PART SPEC.	QTY
1-1	AGC-1001	base seat	底座		1
1-2	AHA-0102	oil tank cover	油箱蓋		1
1-3	PP-90857	cap	油箱蓋螺帽		1
1-4	AGC-1057A	left elec.box cover	左電氣箱蓋		1
1-5		screw	丸頭螺絲	M6*6L	4
1-6	AGC-1054	left rear cover	底座左後蓋		1
1-7		screw	丸頭螺絲	M6*5L	34
1-8	AGC-1052	left cover	底座左蓋		1
1-9	AGC-1053	side cover	底座邊蓋		1
1-10	AGC-1059	coolnat pump cover	水邦浦護蓋		1
1-11	AGC-1050A	right rear cover	底座右後蓋		1
1-12	AGC-1051	right cover	底座右蓋		1
1-13	AGC-1053	side cover	底座邊蓋		1
1-14	AHA-0138	filter	水箱通道濾網		1
1-15		bolt	內六角螺絲	M5*5L	4
1-16	PP-32081	pump	浸水泵浦	1/8HP*210L	1
1-17		bolt	外六角螺絲	M6*10L	4
1-18	AHA-0131	filter	浸水泵浦濾網		1
1-19	AHC-0160	hanger	吊耳(三)		2
1-20		bolt	外六角螺絲	M10*20L	4
1-21	AHC-0161	hanger	吊耳(四)		2
1-22		bolt	外六角螺絲	M10*20L	4
1-23	PP-21030	oil level gauge	油面計	3"	2
1-24		bolt	螺絲		4
1-25	AHA-1309	bracket	軟管架		1
1-26		bolt	內六角螺絲	M6*6L	2
1-27		cable duct	護管	3/8*1000L	1
1-28	AHA-1313	nozzle	噴嘴		1
1-29	AHC-0153	adjusting bolt	底座調整螺絲		6
1-30		nut	螺帽	M20	6
1-31	AHC-1503-NC	right front plate	右前擋板		1
1-32	AHC-1504-NC	right side plate	右側擋板		1
1-33	AHC-0131-CE	elec.box	電氣箱		1
1-34	AGC-1040B	elec.data plate	控制面板		1
1-35	AGC-1041B	control plate	控制底板		1
1-36		screw	丸頭螺絲	M8*8L	4
1-37	AHC-0134-CE	elec.data plate	控制面板		1
1-38	AHC-0135-CE	control plate	控制底板		1
1-39		screw	丸頭螺絲	M8*8L	4
1-40	AHA-1806	vernier dial	流量閥旋鈕		2
1-41	AHA-10289	regulator set	調壓閥		1
1-42	AHA-6100	folw control valve	流量控制閥		1
1-43	AHR-1055	base support	底座墊塊		6
1-44					
1-45	AGC-1048E			Only for CE	1
1-46				Only for CE	1
1-47		Bolt			6

Fig 15 MACHINE FOUNDATION ASSEMBLY(FOR CE)

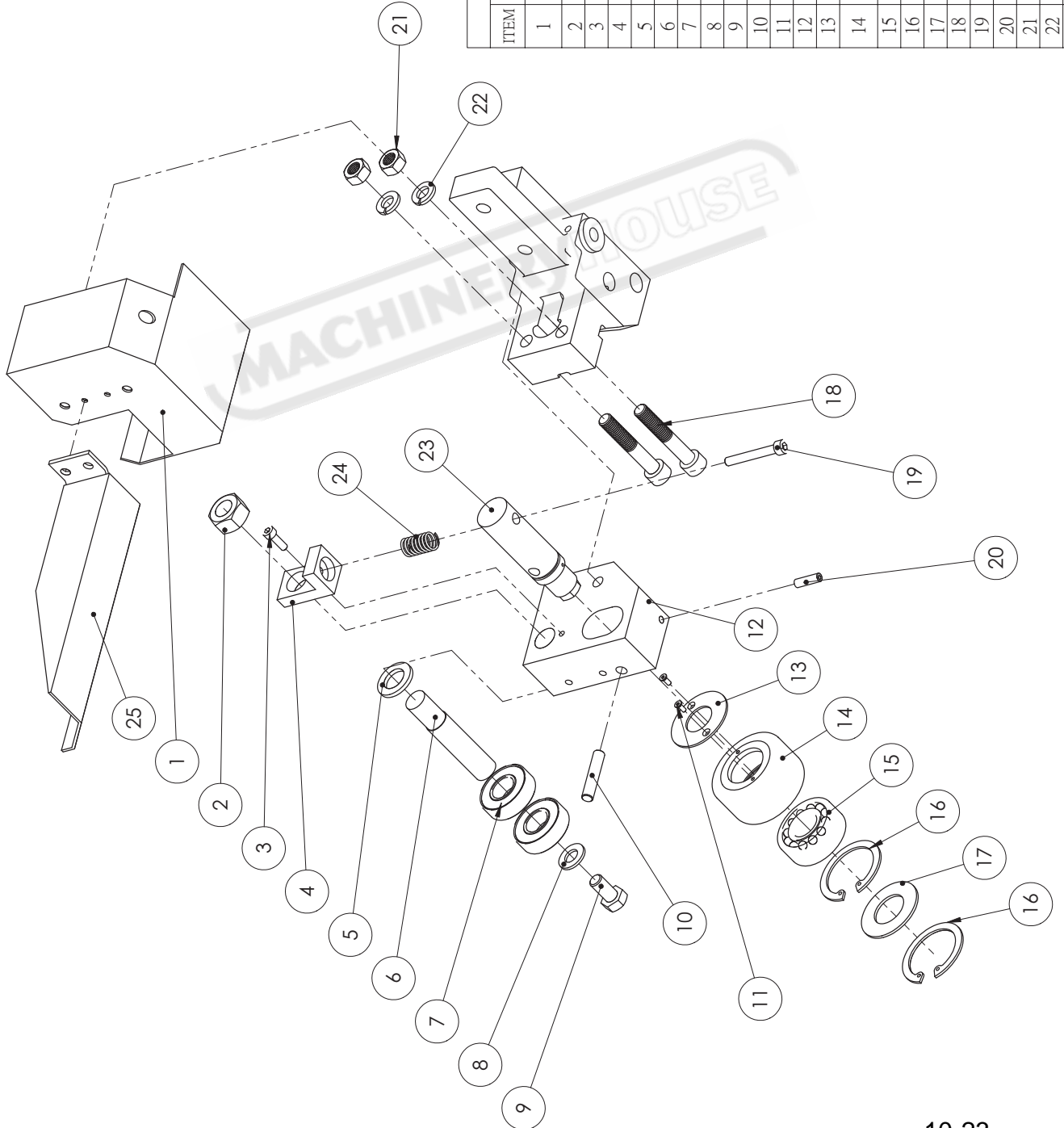

ITEM	PART NO	PART NAME	PART NAME IN CHINESE	PART SPEC	QTY
C320H-42000 防震滾輪組					
1	C320H-4202	Vibration damper cover	防震滾輪護蓋		1
2	POA-16	Nut	螺母(公)	M16xP2.0	1
3	PBA-5-16	Hex soc cap screw	有頭內六角螺絲(公)	M5xP0.8x16	1
4	AGB-3306N	Spring holder	防震彈簧座		1
5	PPA-16	Flat washer	平面華司(公)	Ø16	1
6	AHA-3305	Shaft	固定導輪軸		1
7	PP-14267	Bearing	軸承	6203	2
8	PPA-10	Flat washer	平面華司(公)	Ø10	2
9	PLA-10-20	Hexagon bolt	外六角螺絲(公)	M10xP1.5x20	1
10	PRD-8-40	Pin	平行銷	Ø8x40	1
11	PCA-3-8	Flat screw	平頭內六角螺絲(公)	Ø8x40	1
12	AHA-3303	Vibration damper seat	防震座	M3xP0.5x8	2
13	AGB-3308	Rubber ring	避水橡皮		1
14	AHA-3301	Vibration damper roller	防震導輪		1
15	PP-14507	Bearing	調心軸承	2204	1
16	PP-58111	Snap ring	扣環	R47	2
17	AGB-3307A	Grease cover	牛油擋		1
18	PBA-10-60	Hex soc cap screw	有頭內六角螺絲(公)	M10xP1.5x60	2
19	PBA-6-45	Hex soc cap screw	有頭內六角螺絲(公)	M6xP1.0x45	1
20	PAA-6-20	Set screw	止付螺絲(公)	M6xP1.0x20	1
21	POA-10	Nut	M10螺帽	M10xP1.5	2
22	PQA-10	Spring washer	彈簧華司(公)	Ø10	2
23	AHA-3302	Roller shaft	防震導輪軸		1
24	PP-57403	Spring	彈簧	TH-1625	1
25	C320H-3013	Blade cover	鋸帶護蓋(防震用)		1

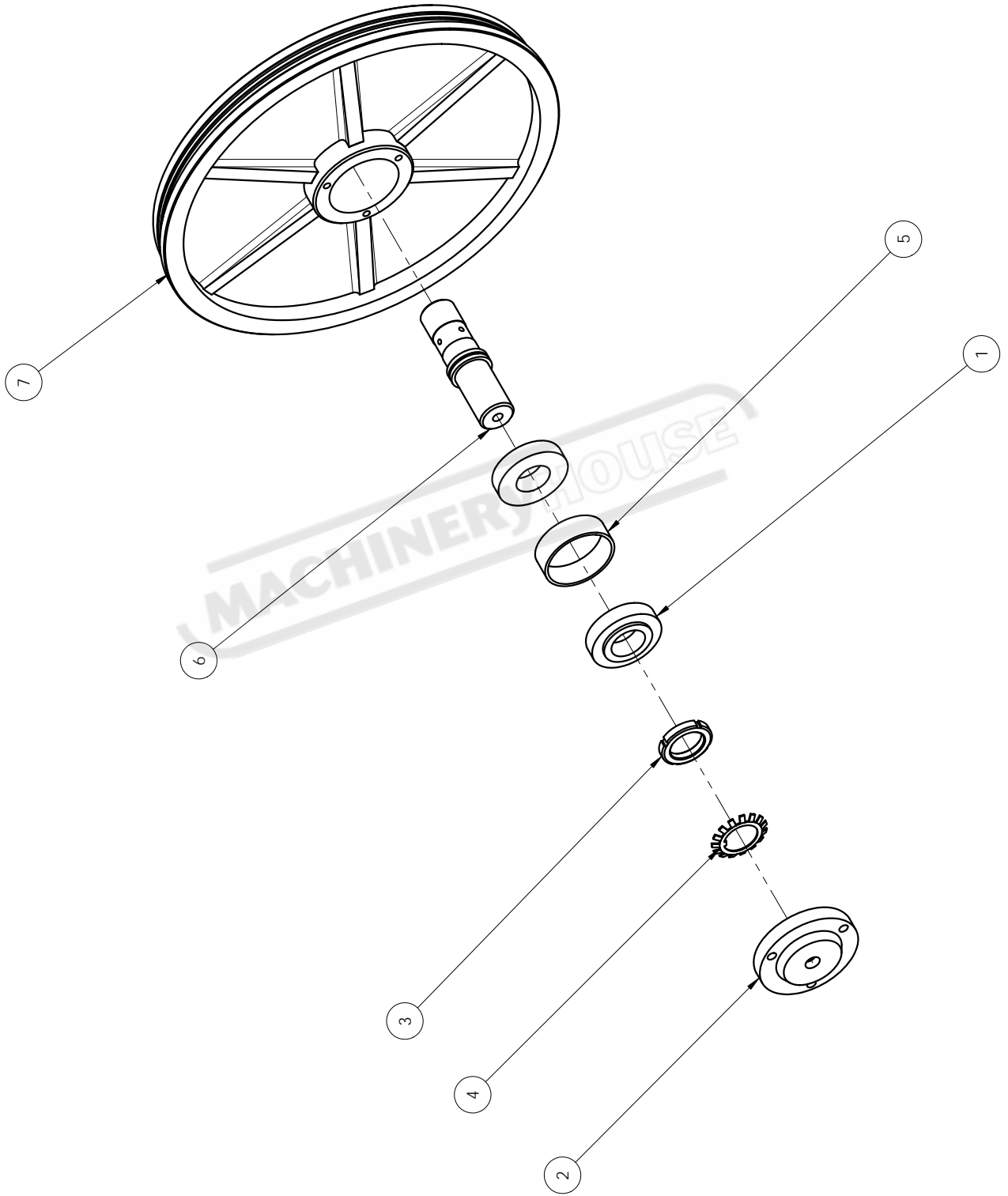

上輪組						
ITME	PART NO.	PART NAME	PART NAME CHINESE	PART SPEC.	QTY	NOTE
1	PP-14613	Ball bearing	滾珠軸承		2	
2	SHA-04140	Idle wheel shaft cover	上輪軸蓋		1	
3	PP-14907	Fixed nut	固定螺母	AN07	1	
4	PP-14957	Stop ring	止動環	AW07	1	
5	AHA-0637	Idle wheel bearing washer	上輪軸承墊圈		1	
6	AHA-0635	Idle wheel shaft	上輪軸		1	
7	AHA-0634B	Idle wheel	上輪		1	

Parts List for C-320NC (B090)

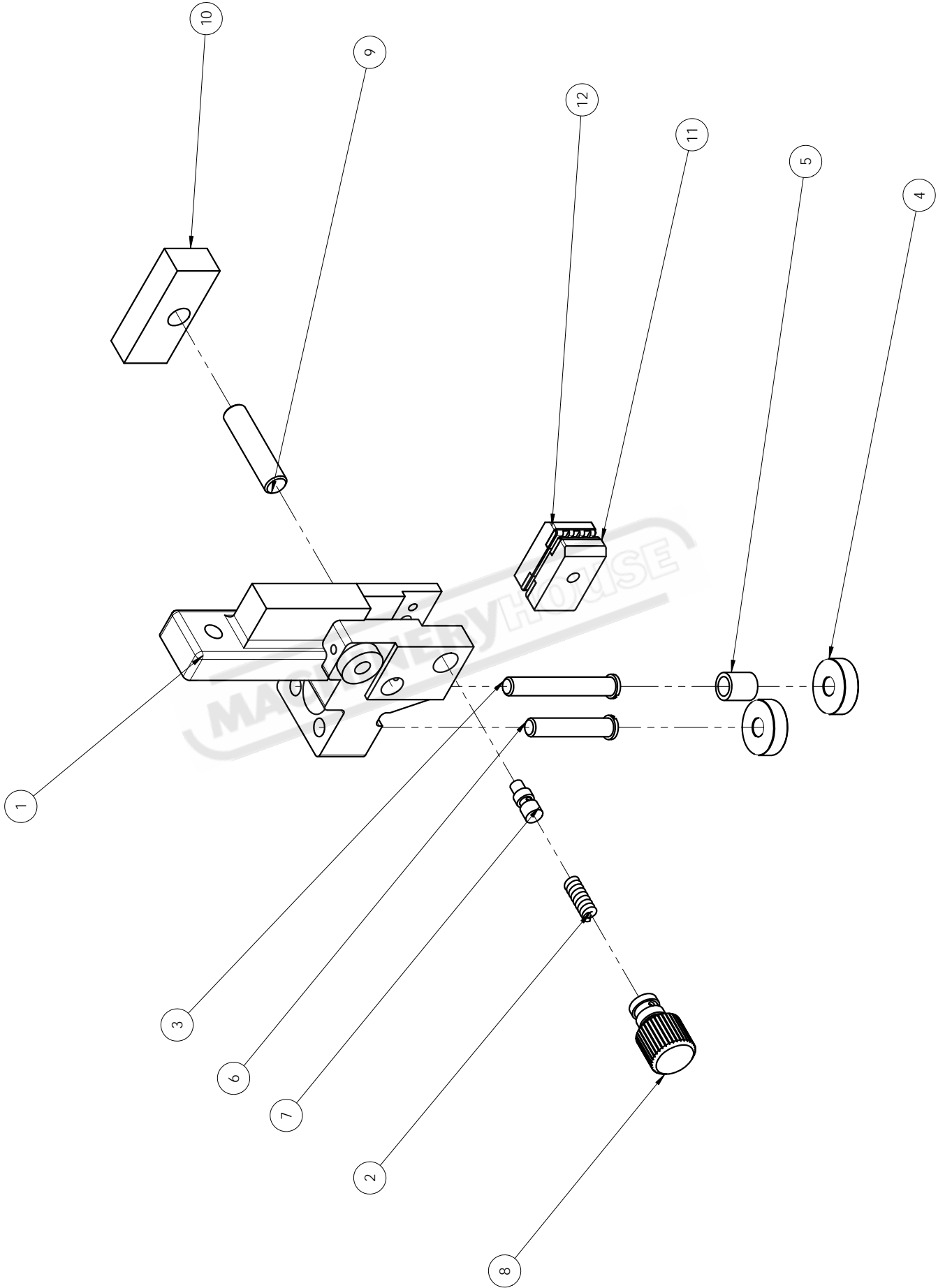

右導輪座組

ITME	PART NO.	PART NAME	PART NAME CHINESE	PART SPEC.	QTY	NOTE
1	AHA-0712B	Left guide roller seat	左導輪座		1	
2	AHA-0710	Carbide insert spring	彈簧(鎢鋼片)		1	
3	AHA-0707B	Guide roller shaft	導輪軸		1	
4	PP-14270B	Bearing	軸承	6200	2	
5	AHA-0708B	Washer	導輪墊圈		1	
6	AHA-0707C	Guide roller shaft(3)	導輪軸(三)		1	
7	AHA-0709	Left spring plug	左簧塞		1	
8	AHA-0711A	Adjusting screw-left	左調整螺絲		1	
9	AHA-0713-1	Ficed shaft	軸承座固定銷		1	
10	AHA-0704A	Pressure block	下壓座		1	
11	AHA-0702B	Left movable insert	左活動鎢鋼片		1	
12	AHA-0701B	Left fixed insert	左固定鎢鋼片		1	

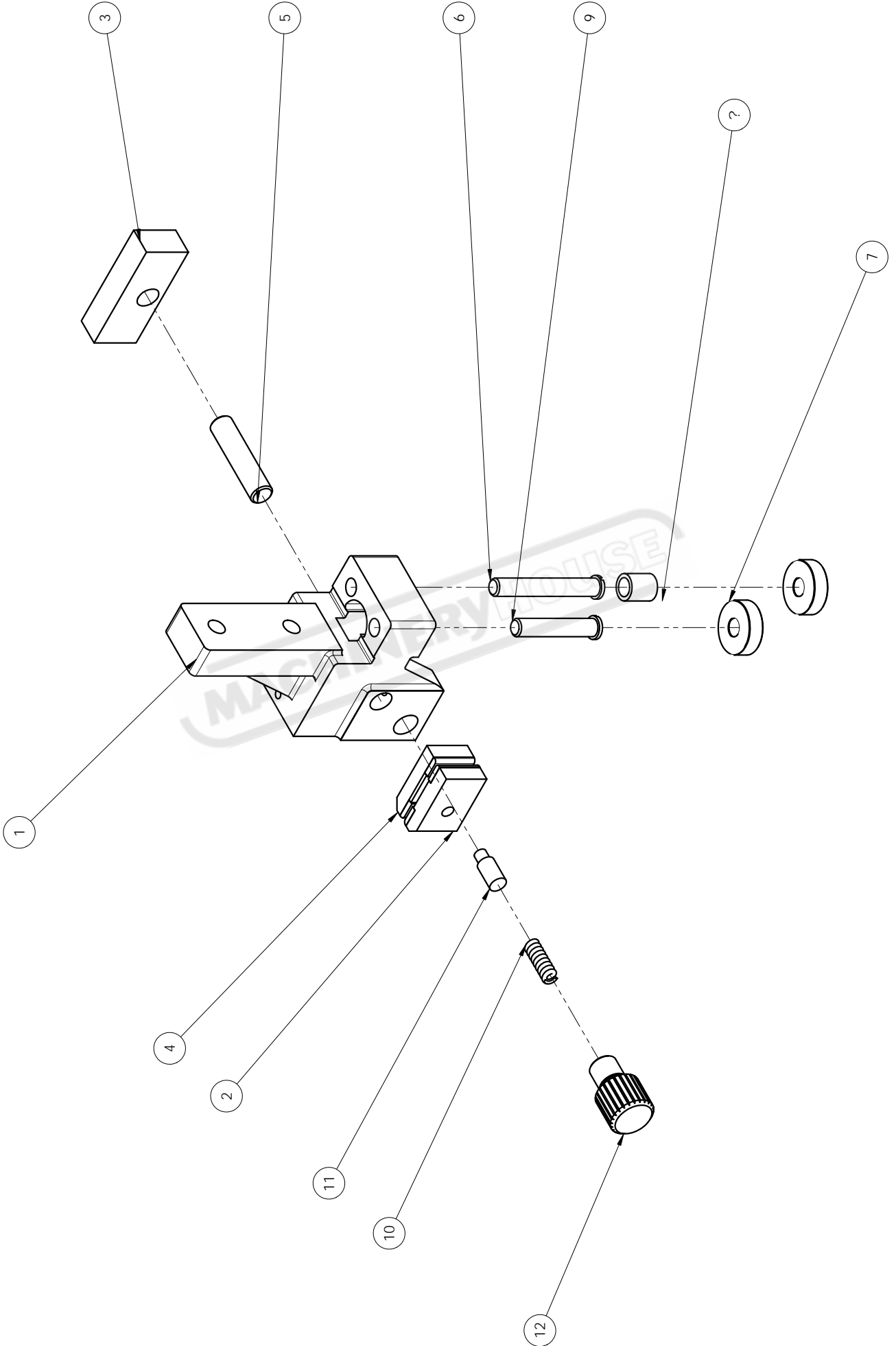

左導輪座組

ITME	PART NO.	PART NAME	PART NAME CHINESE	PART SPEC.	QTY	NOTE
1	AHA-0748B-S2	Right guide roller seat	右導輪座		1	
2	AHA-0743B	Right movable insert	右活動錫鋼片		1	
3	AHA-0704A	Pressure block	下壓座		1	
4	AHA-0744B	Right fixed insert	右固定錫鋼片		1	
5	AHA-0713-1	Ficed shaft	軸承座固定銷		1	
6	AHA-0707B	Guide roller shaft	導輪軸		1	
7	PP-14270B	Bearing	軸承	6200	2	
8	AHA-0708B	Washer	導輪墊圈		1	
9	AHA-0707C	Guide roller shaft(3)	導輪軸(三)		1	
10	AHA-0710	Carbide insert spring	彈簧(錫鋼片)		1	
11	AHA-0741	Rigjt spring plug	右簧塞		1	
12	AHA-0742	Adjusting screw-right	右調整螺絲		1	



C-320NC 底座組 SERIES PART LIST

2018/10/19

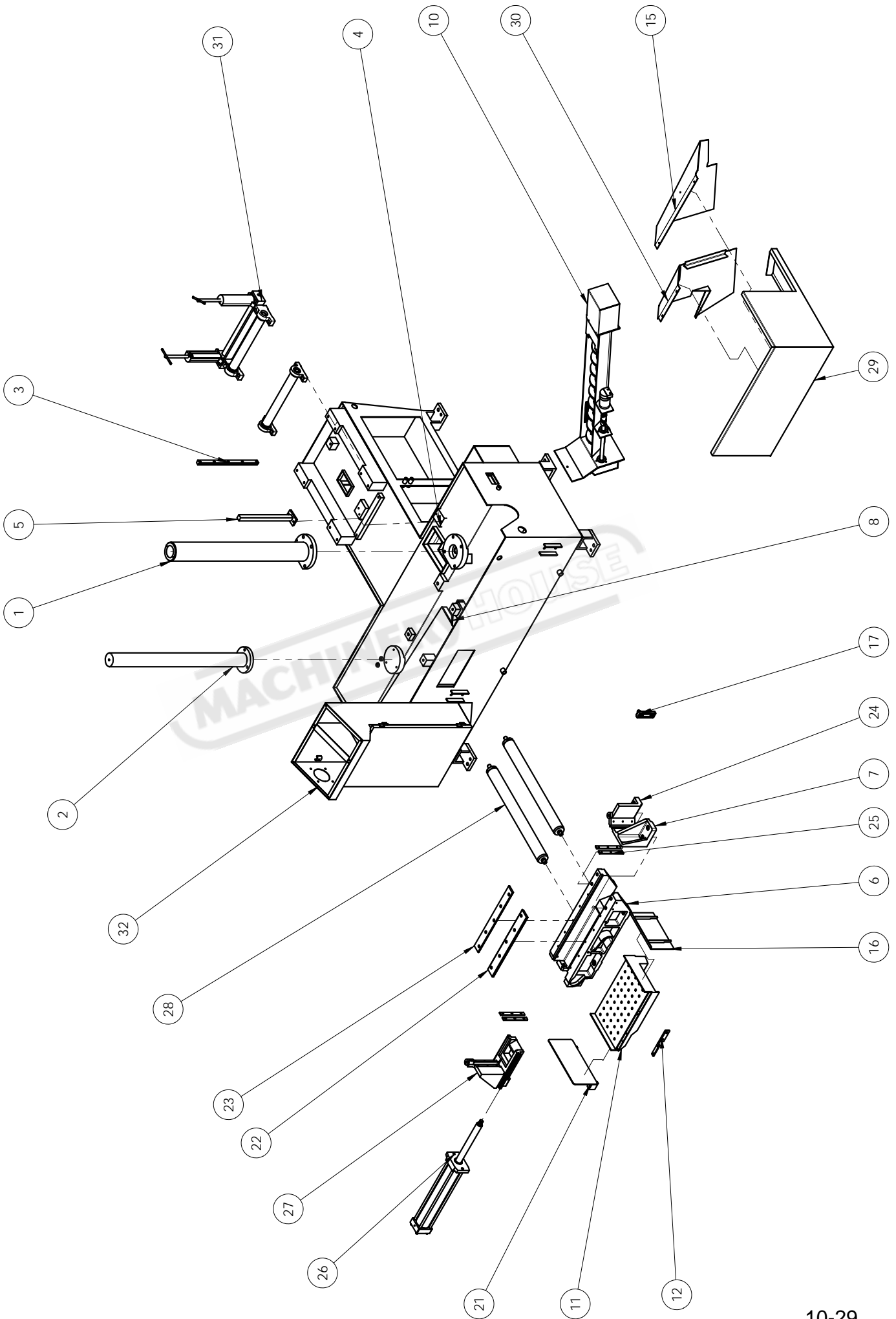

底座組						
ITME	PART NO.	PART NAME	PART NAME CHINESE	PART SPEC.	QTY	NOTE
1	AGC-1010	Main shaft	大主軸		1	
2	AGC-1011	Sub shaft	小主軸		1	
3	C320G-21000	Height encoder assembly	高度驛碼器		1	
4	AGC-1034-NC	fixed block	中限固定塊		1	
5	AHK-1905-NC	Base plate	中限固定座		1	
6	AHC-0201	Bed	床面		1	
7	AHC-0230	Front fixed vise 2	前固定虎鉗(二)		1	
8	C320H-1001	Base	底座		1	
9	C320H-4009	Fixed bracket	除屑機固定板		1	
10	C320H-40000-1	Chip conveyor assembly	除屑機組 (整組外購)		1	
11	AGC-1035	Bracket	托架		1	

Parts List for C-320NC (B090)

底座組						
ITME	PART NO.	PART NAME	PART NAME CHINESE	PART SPEC.	QTY	NOTE
12	AHC-1437	Supporter	托架支持板		1	
13	C320H-4008		前導屑板		1	
14	C320H-1504B		右側擋板		1	
15	C320H-1045	Catchment plate	集水板-2		1	
16	AHC-1424	Right bracket	托架右板		1	
17	PP-21030	Oil sight gauge	油面計	3"	1	
18	C320H-1043A	Catchment plate	集水板		1	
19	C320H-2009A	Chip collector	集屑板		1	
20	C320H-1042	Catchment plate	集水板		1	
21	AHC-1423-CE	Left bracket	托架左板		1	
22	AHC-0234A	Bed steel plate	床面鋼板(一)		1	

Parts List for C-320NC (B090)

底座組						
ITME	PART NO.	PART NAME	PART NAME CHINESE	PART SPEC.	QTY	NOTE
23	AHC-0234B	Bed steel plate	床面鋼板(二)		1	
24	AHC-0229	Front fixed vise 1	前固定虎鉗(一)		1	
25	AHC-0239D	Vise steel plate	虎鉗鋼板		4	
26	AGC-2300	Vise hydraulic cylinder	虎鉗油壓缸組		1	
27	AHC-0223-NC	Front movable vise	前活動虎鉗		1	
28	AHA-1601B	Feeding shaft	送料軸		2	
29	AGC-1058-CE		除屑擋板		1	
30	C320H-1044	Catchment plate	集水板-1		1	
31		Feeding roller assembly	送料滾輪座組		1	
32	AHC-0131-CE	Control box	控制箱		1	

Parts List for C-320NC (B090)

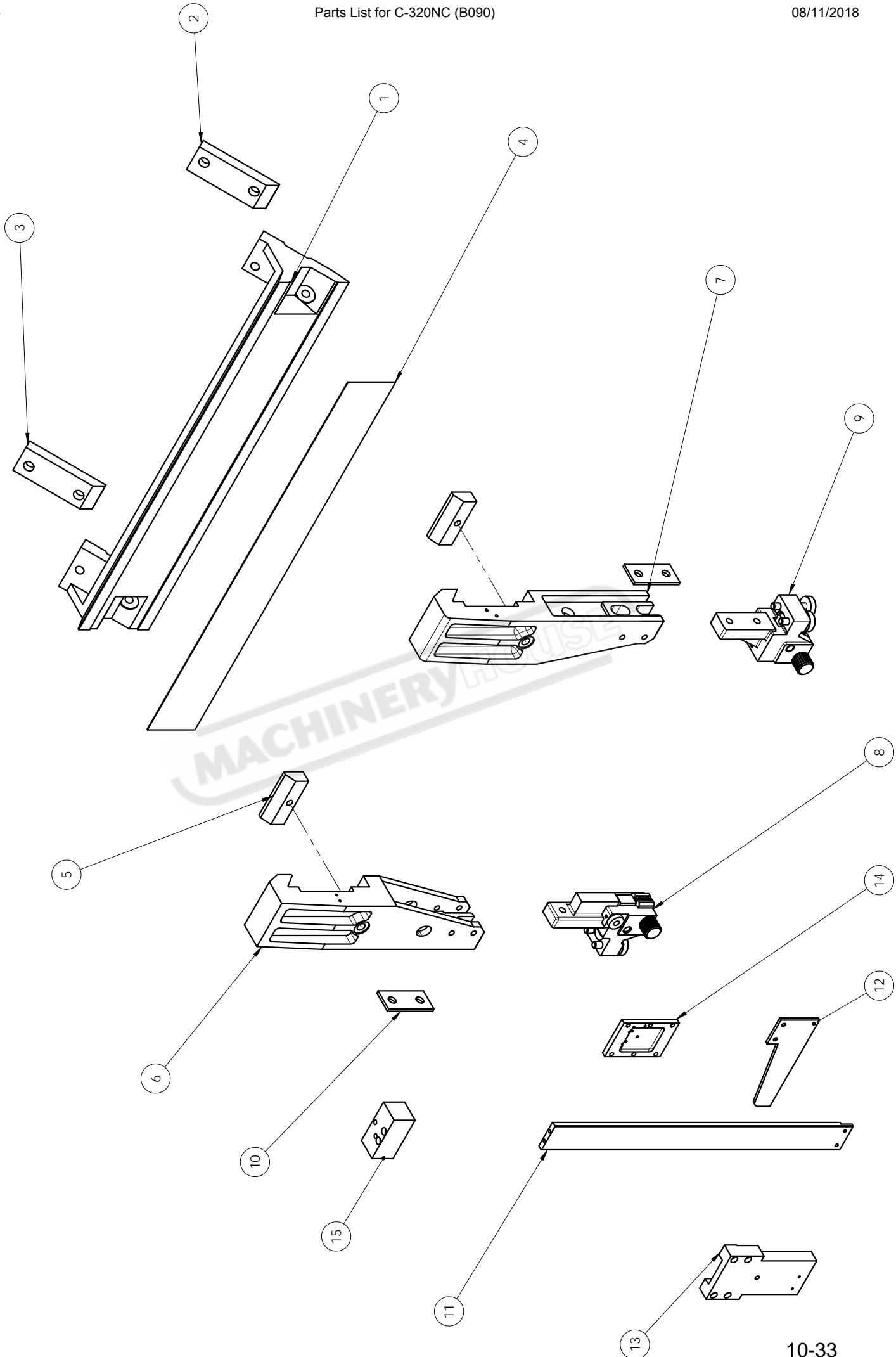

活動鋸臂組

ITME	PART NO.	PART NAME	PART NAME CHINESE	PART SPEC.	QTY	NOTE
1	AHC-0738	Guide arm sliding plate	鋸臂滑板		1	
2	AHA-0439B	Guide arm sliding plate	鋸臂滑板固定塊(二)		1	
3	AHA-0439A	Guide arm sliding plate	鋸臂滑板固定塊(一)		1	
4	AGC-3018	Saw arm sliding board	鋸臂滑板銘牌		1	
5	AHA-0737	Guide arm fixed block	鋸臂固定塊		2	
6	AHC-0722	Left guide arm	左鋸臂		1	
7	AHC-0749	Right guide arm	右鋸臂		1	
8		Right guide roller assembly	右導輪座組		1	
9		Left guide roller assembly	左導輪座組		1	
10	AHA-0719	Spacer	導輪座墊板		2	

Parts List for C-320NC (B090)

活動鋸臂組						
ITME	PART NO.	PART NAME	PART NAME CHINESE	PART SPEC.	QTY	NOTE
11	AHC-1753B	Descending slide bar	急降桿		1	
12	AHA-1755C	Feeder	急降桿擋板		1	
13	AHA-1752	Descending slide bracket	急降桿固定座		1	
14	AHA-1754	Cover plate	急降桿座蓋		1	
15	AHA-1756	Limit block	限動開關座		1	

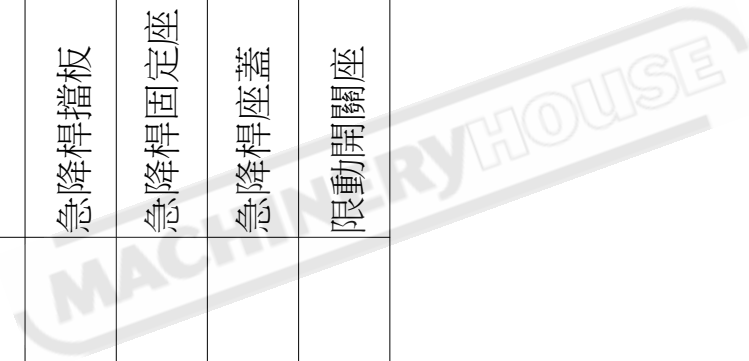

2018/10/19

C-320NC SERIES PART LIST

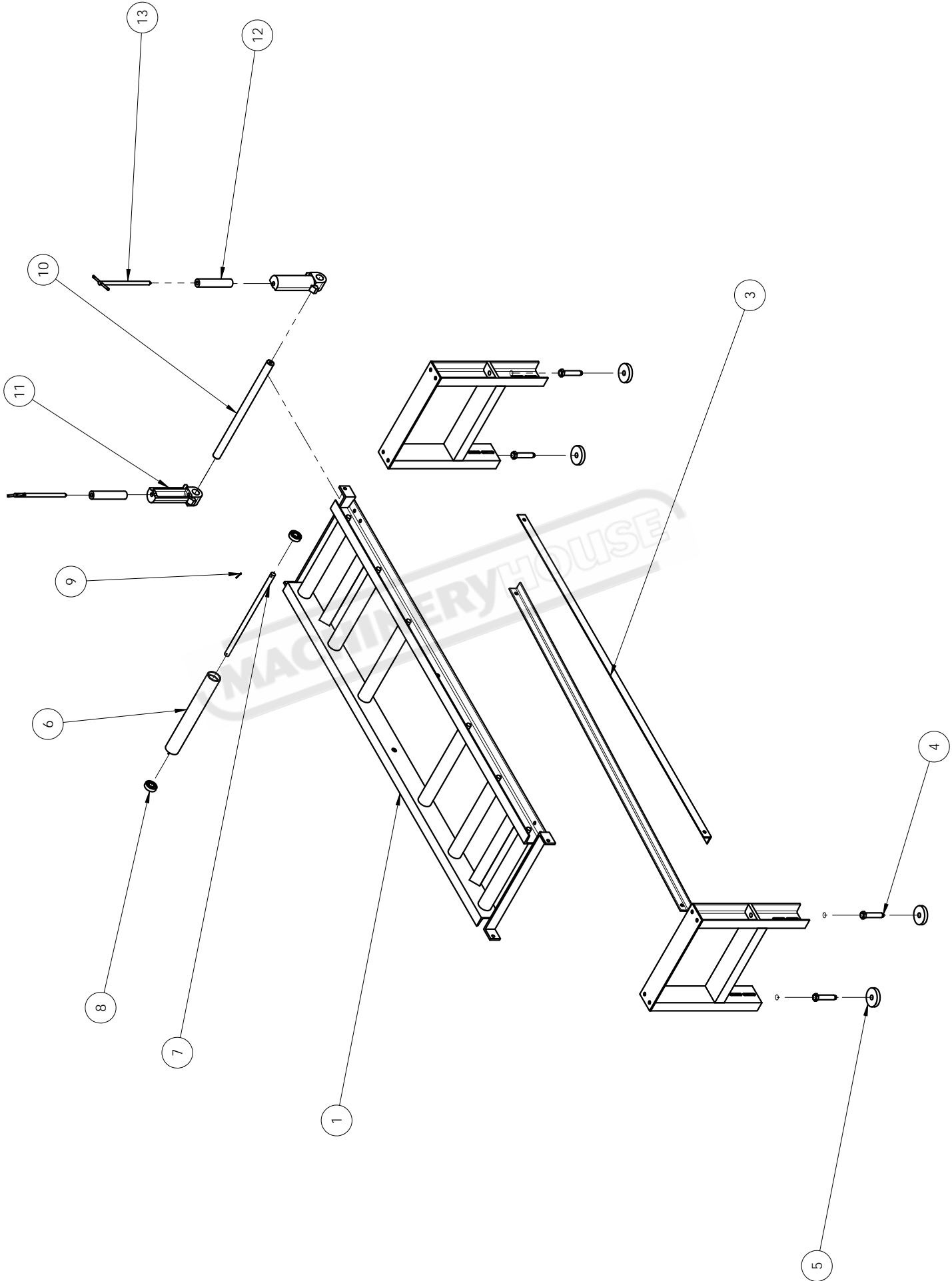

ITME	PART NO.	PART NAME	PART NAME CHINESE	PART SPEC.	QTY	NOTE
1	RC4460-5002	Roller frame	滾輪料架		1	
2	RC4460-5003		固定腳架		2	
3	RC4460-5004	Roller table foot connecting rod	料架腳連桿		2	
4	AHC-0152	Table stand adjusting rod	送料架調整螺桿		4	
5	AHR-1055	Table stand pad	底座墊塊		4	
6	RC4460-5001	Roller	滾輪		7	
7	OPR-5009A	Roller shaft	滾輪軸		7	
8	PP-14297A	Bearing	軸承	6304	14	
9	PUA-007-140	Split pin	開口銷		14	
10	OPR-5008A	Vertical roller sliding shaft	側滾輪滑軸		1	
11	OPR-5015B	Vertical roller seat	側滾輪座		2	
12	OPR-5013B	Vertical roller	側滾輪		2	
13	OPR-5014B	Vertical roller shaft	側滾輪軸及把手		2	

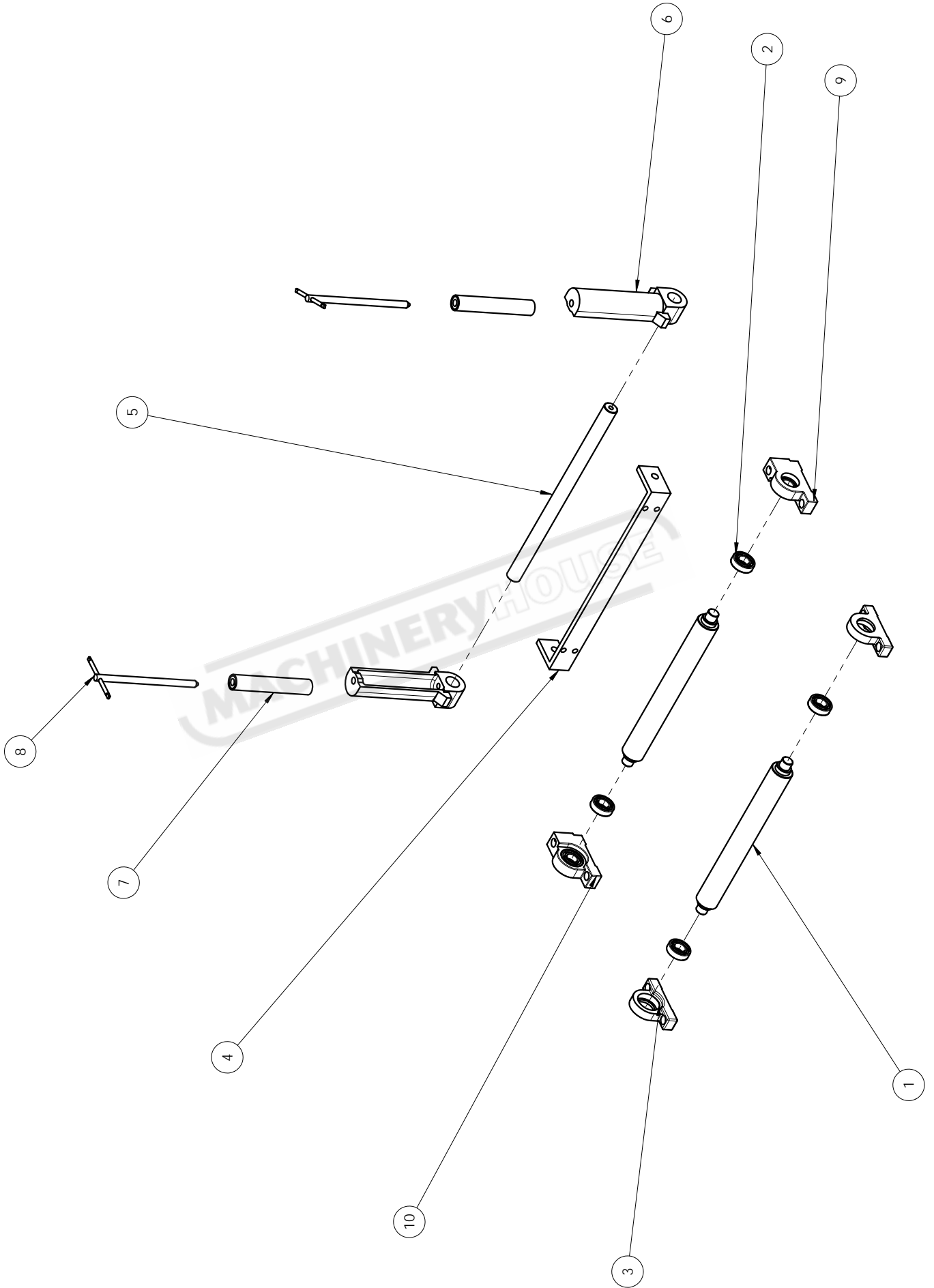

送料滾輪座組						
ITME	PART NO.	PART NAME	PART NAME CHINESE	PART SPEC.	QTY	NOTE
1	AHB-1654A	Roller	滾輪		2	
2	PP-14275	Bearing	軸承		4	
3	AHA-1636	Roller fixed seat	滾輪固定座		2	
4	AGC-1064	Side roller stopper	側滾輪擋板		1	
5	AGC-1065	Vertical roller sliding shaft	側滾輪滑軸		1	
6	OPR-5015B	Vertical roller seat	側滾輪座		2	
7	OPR-5013C	Vertical roller	側滾輪		2	
8	OPR-5014B	Vertical roller shaft	側滾輪軸及把手		2	
9	AHB-16530	Roller fixed seat(right)	滾輪固定座(右)		1	
10	AHB-16560	Roller fixed seat(left)	滾輪固定座(左)		1	

Parts List for C-320NC (B090)

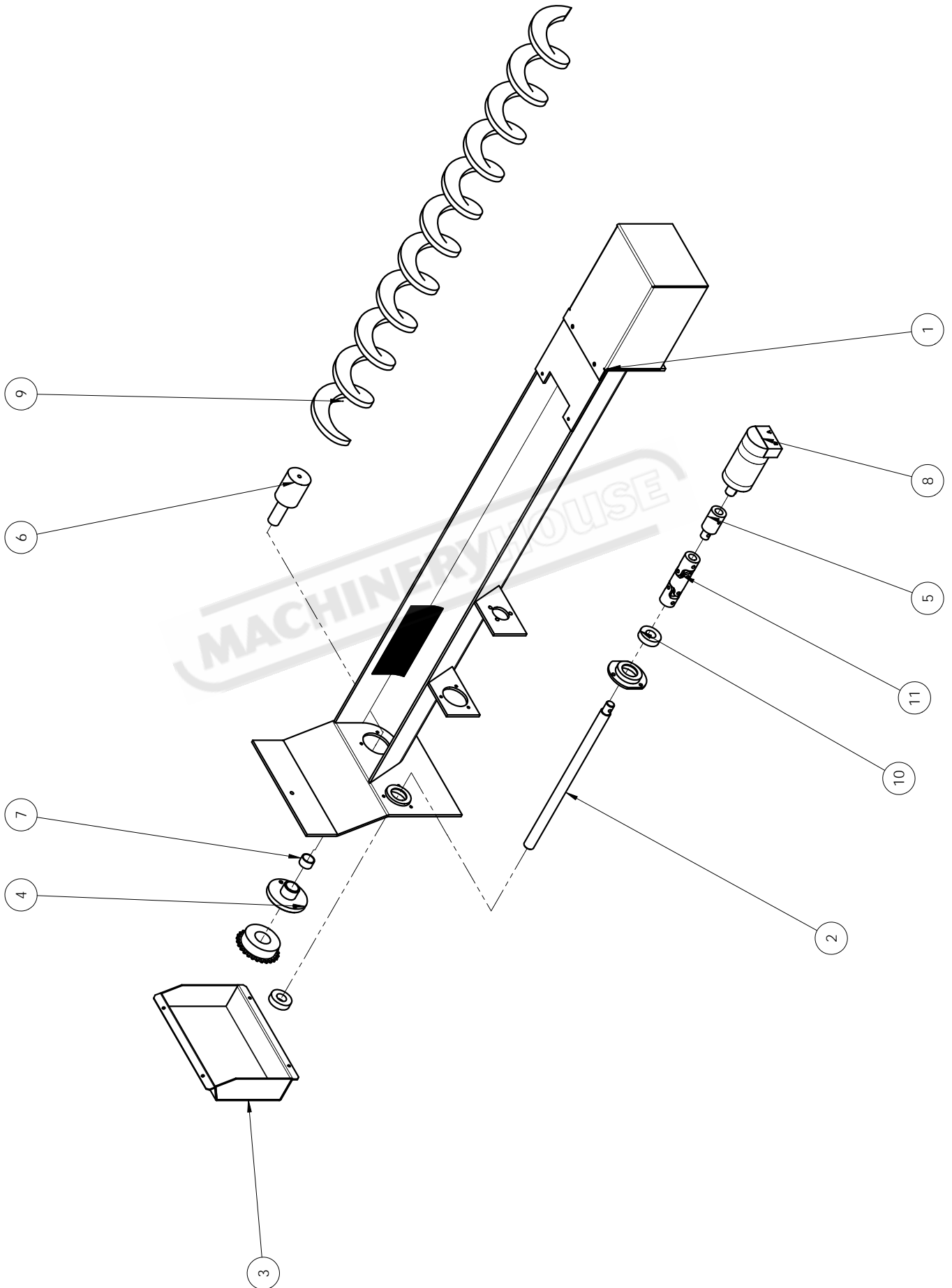

除屑機組						
ITME	PART NO.	PART NAME	PART NAME CHINESE	PART SPEC.	QTY	NOTE
1	C320H-40000-1	Chip conveyor body	除屑機本體		1	
2	AHN-1403	Core shaft	傳動心軸		1	
3	AHN-1407A		鏈齒蓋板		1	
4	AHN-1411	Shsft seat	軸座		1	
5	AHN-1414	Connecting shaft	連接軸		1	
6	C520H-4051	Chip screw rod	除屑螺桿		1	
7	PP-13119	Bearing	自潤軸承	2215	1	
8	PP-31640-1	Hydraulic motor	油壓馬達	MMS-32C	1	
9	S1713-4003C	Chip spiral	除屑螺旋		1	
10	PP-14252	Bearing	軸承	6004ZZ	2	
11	PP-15031	Universal joint	萬向接頭		1	

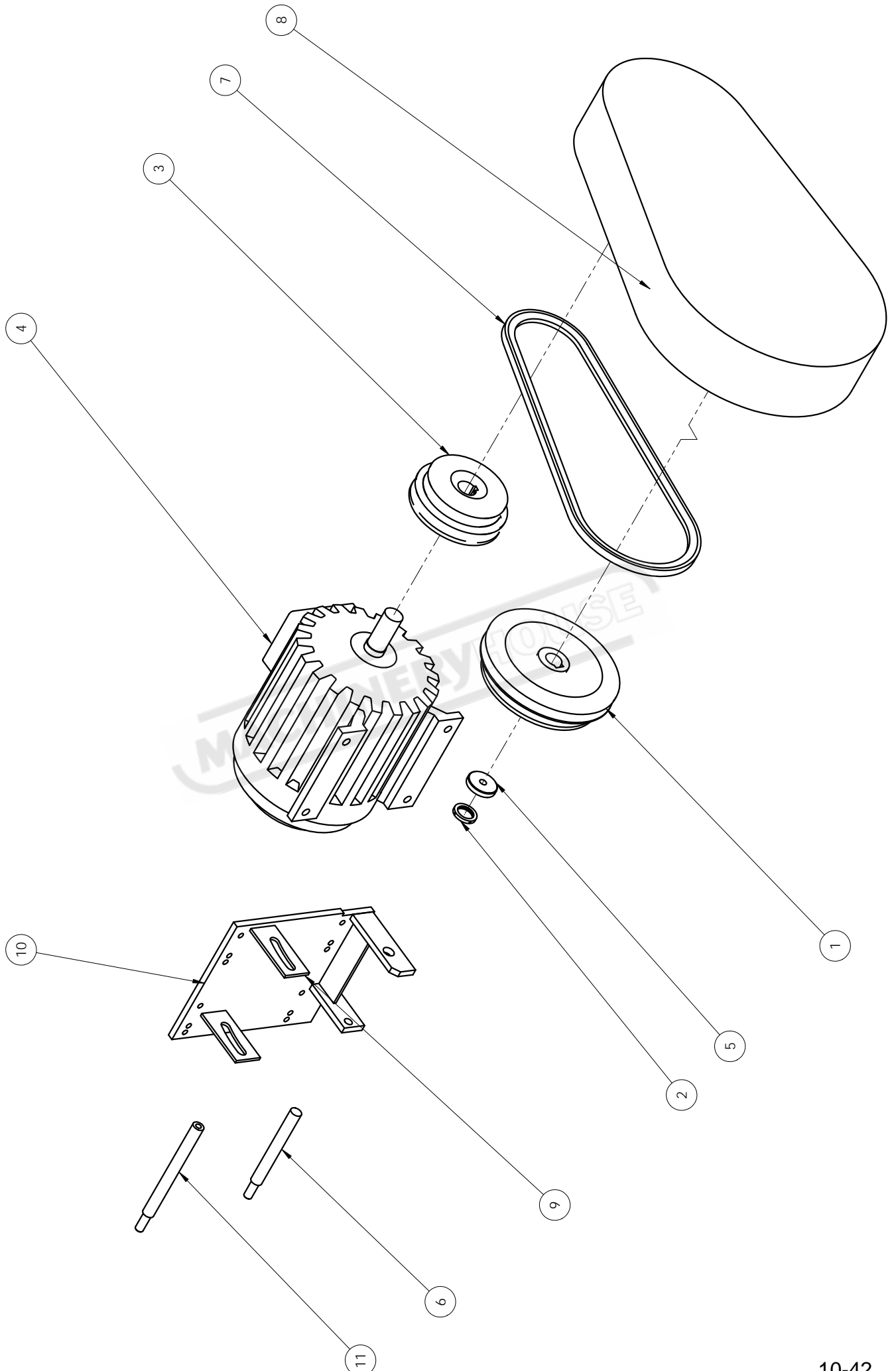

馬達組

ITME	PART NO.	PART NAME	PART NAME CHINESE	PART SPEC.	QTY	NOTE
1	AHA-0514G	Transmission puley	減速機普利		1	
2	MAE-2025	Idle wheel shaft washer	上輪軸墊圈		1	
3	AHA-0538G	Motor belt wheel	馬達皮帶輪		1	
4	PBH5-D414-C	Motor	馬達		1	
5	AHA-0525	Washer	墊圈		1	
6	AHA-0515	Motor movable shaft	馬達活動軸		1	
7	PP-56287	Belt	皮帶		1	
8	AHC-0501	Pulley cover	普利護蓋		1	
9	AHA-0510B		馬達底板耳		2	
10	AHR-2027	Pulley cover	馬達底板		1	
11	AHA-0526	Motor position shaft	馬達定位軸		1	

Parts List for C-320NC (B090)

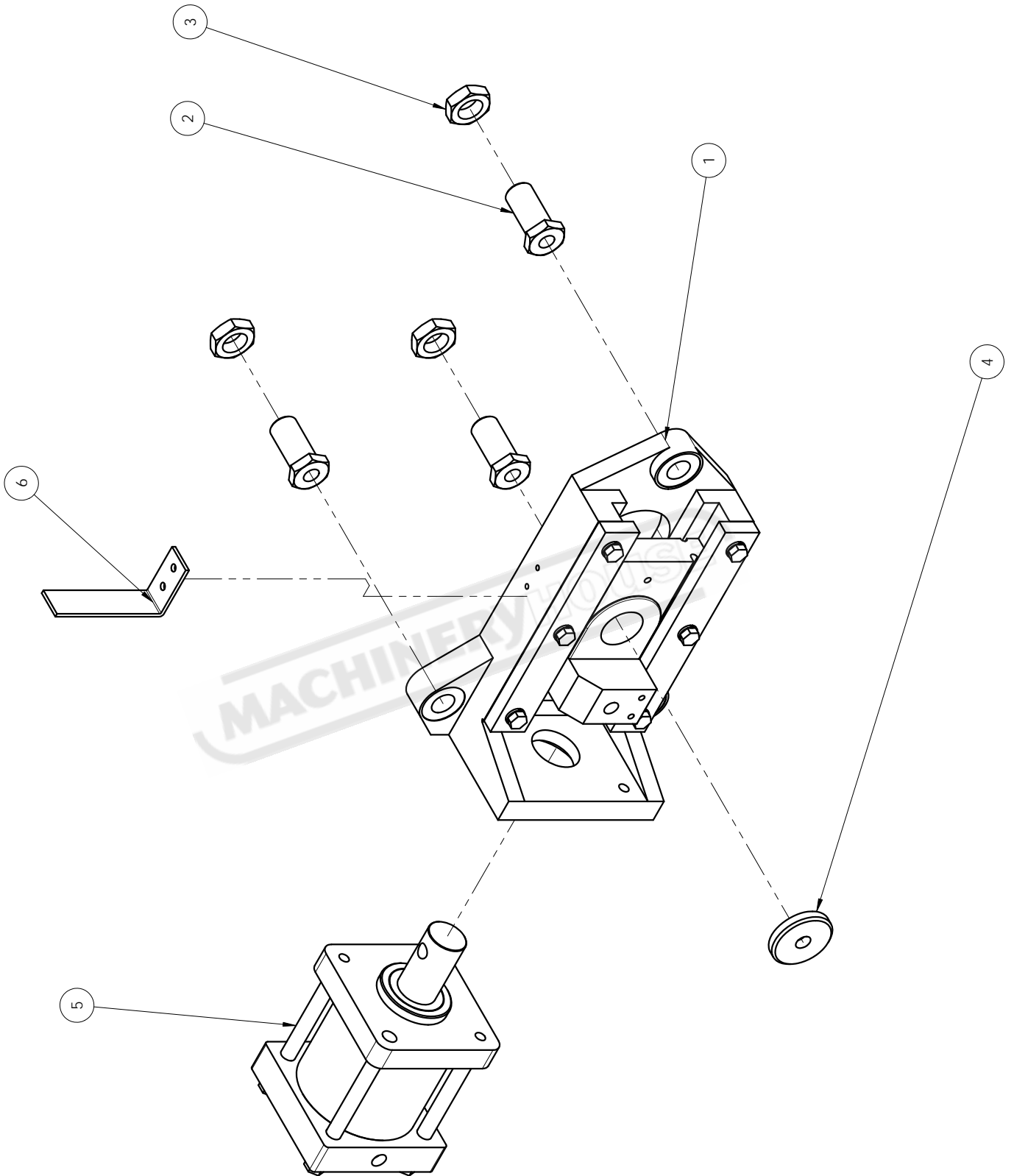

張力滑座滑板組						
ITME	PART NO.	PART NAME	PART NAME CHINESE	PART SPEC.	QTY	NOTE
1	AHA-06029	Tensioner sliding plate	張力滑座滑板組		1	
2	AHA-0610	Adjusting screw	調整螺絲		3	
3	AHA-0611	Adjusting nut	調整螺母		3	
4	AHA-0403	Washer	下輪鎖緊墊圈		1	
5	AHA-06189-1	Tensioner cylinder assembly	張力油壓缸組		1	
6	AHA-0670A	Sensor seat	感應器底板座		1	



C-320NC 減速機組 SERIES PART LIST

2018/10/19

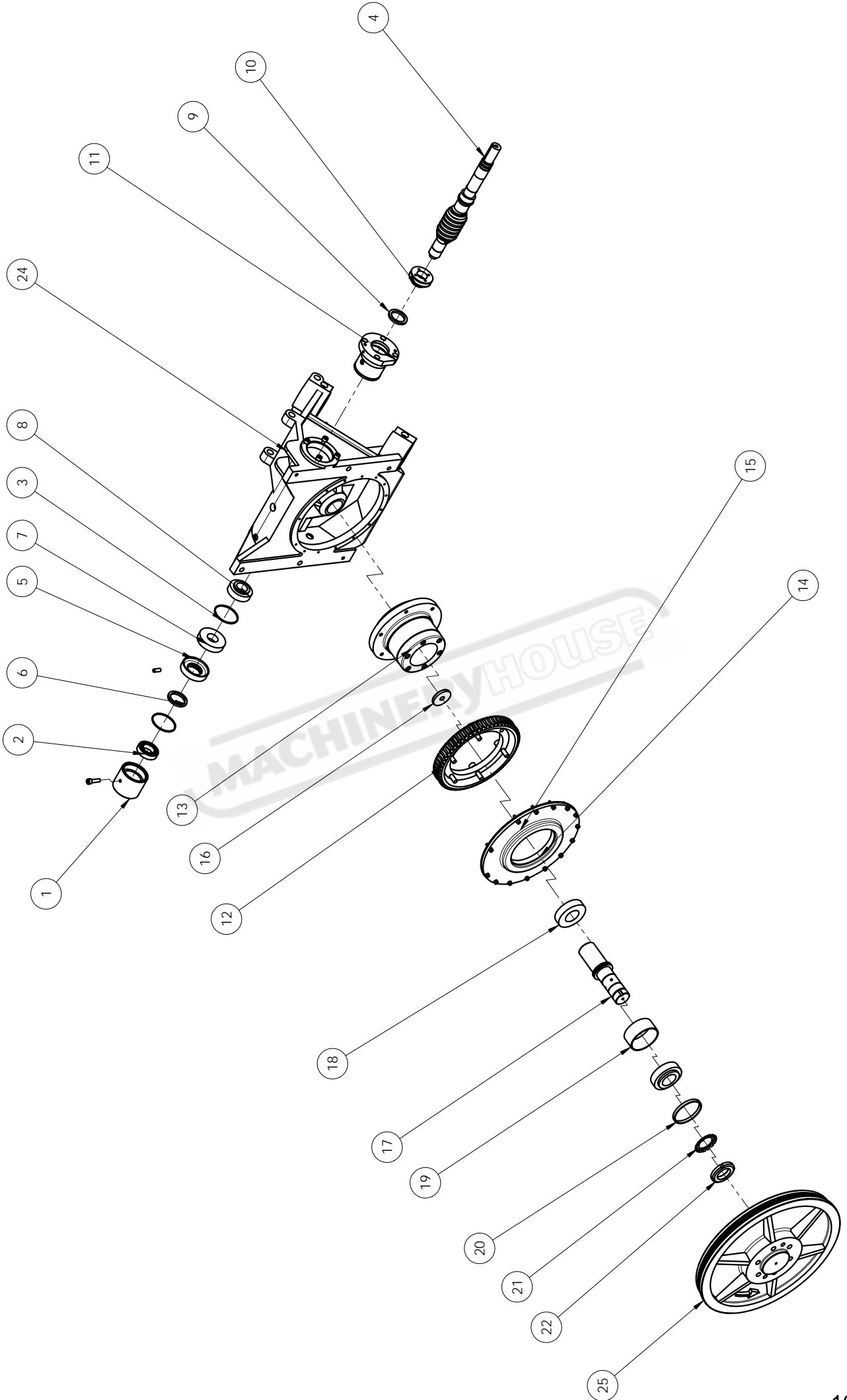

減速機組

ITME	PART NO.	PART NAME	PART NAME CHINESE	PART SPEC.	QTY	NOTE
1	AHA-0326	Fixed seat (2)	固定座(二)		1	
2	PP-14142A	Bearing	軸承	6006ZZ	1	
3	PP-58103	Interlock	扣環	R62	2	
4	AHA-0305	Worm gear	蝸桿		1	
5	AHA-0314	Fixed seat cover	固定座蓋		1	
6	PP-51080	Oil seal	油封		1	
7	PP-14652	Ball bearing	滾錐軸承	30306D	1	
8	PP-14691	Ball bearing	滾錐軸承	32206	1	
9	PP-51070	Oil seal	油封		1	
10	AHA-0320	Wire brush pulley	鋼刷普利		1	
11	AHA-0319	Fixed seat (1)	固定座(一)		1	

Parts List for C-320NC (B090)

減速機組

ITME	PART NO.	PART NAME	PART NAME CHINESE	PART SPEC.	QTY	NOTE
12	AHA-0404	Worm gear	蝸桿		1	
13	C250H-3365	Worm gear seat	蝸輪固定座		1	
14	PP-51090A	Oil seal	油封		1	
15	AHA-0433A	Oil fixed plate	油封固定盤		1	
16	AHA-0403	Washer	下輪鎖緊墊圈		1	
17	AHA-0407	Drive wheel shaft	下輪軸		1	
18	PP-14693B	Ball bearing	滾錐軸承	32208	2	
19	AHA-0431	Bearing washer	軸承墊圈		1	
20	AHA-0429	Adjusting ring	調整環		1	
21	PP-14958	Stop ring	止動環		1	
22	PP-14908	Fixed nut	固定螺母	AN08	1	

Parts List for C-320NC (B090)

減速機組						
ITME	PART NO.	PART NAME	PART NAME CHINESE	PART SPEC.	QTY	NOTE
23	AHA-0454	Rubber washer	橡膠墊圈		1	
24	AGC-3008	Gear reducer body	減速機本體		1	
25	AHA-0416B	Drine wheel	下輪		1	

MACHINERYHOUSE

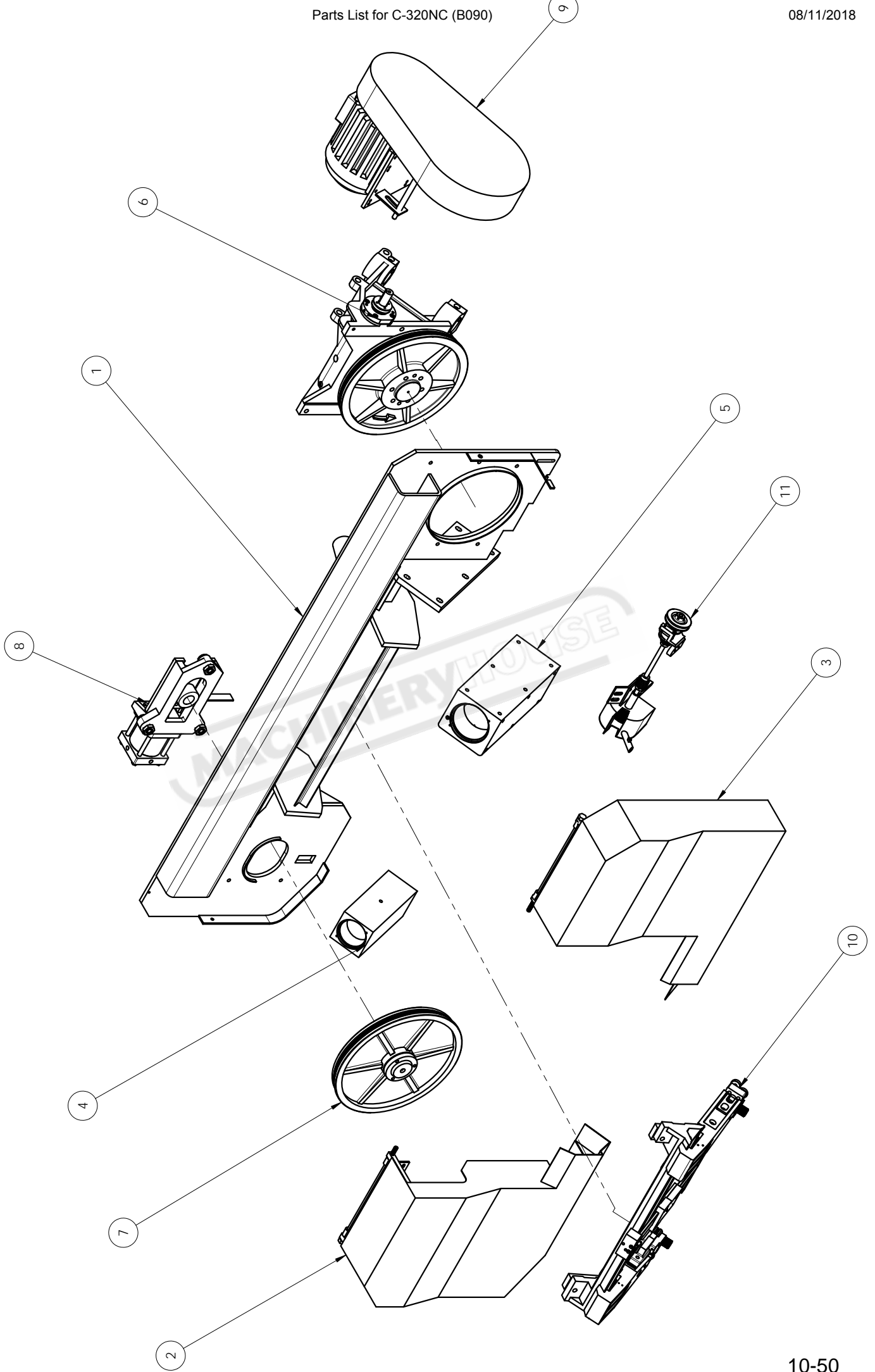

鋸弓組						
ITME	PART NO.	PART NAME	PART NAME CHINESE	PART SPEC.	QTY	NOTE
1	AGC-3001	Saw bow	鋸弓		1	
2	AGC-3002A	Idle wheel cover	上輪箱蓋		1	
3	AGC-3003A	Drive wheel cover	下輪箱蓋		1	
4	AGC-3010	Sub shaft sleeve	小軸套		1	
5	AHP-1801A	Main shaft sleeve	大軸套		1	
6		Gear reducer assembly	減速機組		1	
7		Idle wheel assembly	上輪組		1	
8		Tensioner sliding plate	張力滑座滑板組		1	
9		Motor assembly	馬達組		1	
10		Saw arm assembly	鋸臂組		1	
11		Wire brush assembly	鋼刷除屑組		1	

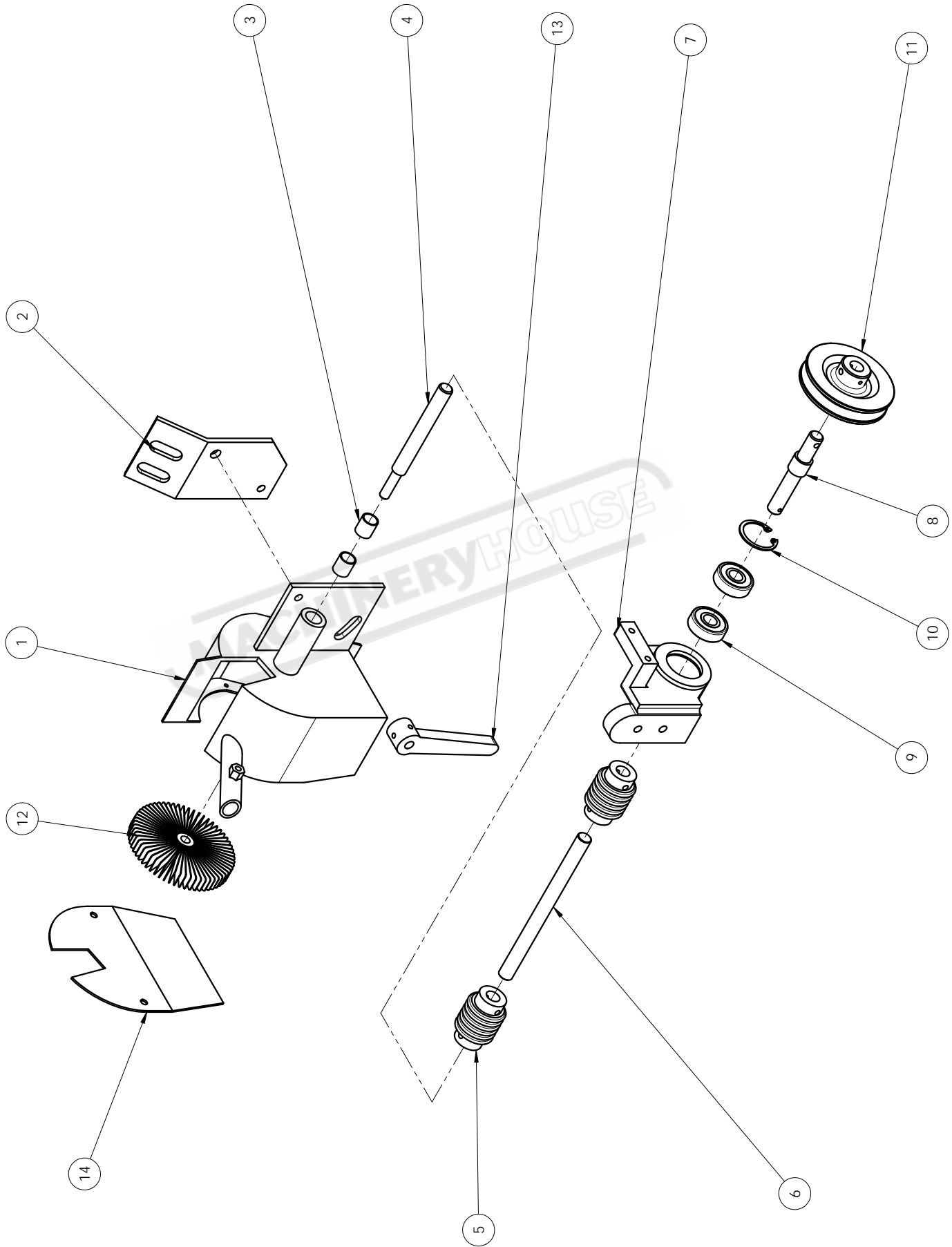
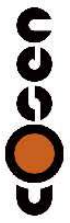

鋼刷組

ITME	PART NO.	PART NAME	PART NAME CHINESE	PART SPEC.	QTY	NOTE
1	AGC-3025	Wire brush cover	鋼刷護蓋		1	
2	C320H-3246	Brush cover fixed plate	鋼刷護蓋固定板		1	
3	PP-13025	DU bearing	乾式軸承	1215	2	
4	AHB-0519	Wire brush shaft	鋼刷軸		1	
5	PP-15010	Universal joint	萬向接頭	12MM	2	
6	AGC-3026	Wire brush transmission shaft	鋼刷傳動桿		1	
7	AHA-12110-1	Wire brush bearing seat	鋼刷軸承座組		1	
8	AHA-1207	Belt wheel shaft	皮帶輪軸		1	
9	PP-14272	Bearing	軸承	6201V	2	
10	PP-58109	Snap ring	扣環	R32	1	
11	AHA-1202	Belt wheel	鋼刷皮帶輪		1	

Parts List for C-320NC (B090)

鋼刷組						
ITME	PART NO.	PART NAME	PART NAME CHINESE	PART SPEC.	QTY	NOTE
12	PP-58002	Wire btush	鋼刷	90mm*8mm*16T	1	
13	AHA-1217	Wire brush fixed handle	鋼刷調整桿		1	
14	AHA-1220-2	Wire brush cover plate	鋼刷護蓋板		1	

